

DPC-510 PRESSURE VOLUME CONTROL

- One precision pressure sensors built in
- Ultra low pressure or volume control
- High accuracy measurement repeatability
- Long term sensor stability and auto zero
- Password protected keyboard and display
- Analog and digital interface with BMS
- High and low Alarm thresholds and timers
- Volt free contacts for remote alarms
- Door switch control freeze with timer
- Two Modbus rtu communication networks
- After Sales Service is provided by CMR
- 24 month warranty
- 30 Years field application experience



DPC-510 Pressure-Volume Controller with one built in Sensor

GENERAL

The DPC510 provides accurate air volume and room pressure control in process control applications such as clean rooms, laboratories, high containment facilities and many commercial applications.

The secret of the high accuracy measurements is the built in CMR pressure and volume transducer which has proven itself also in harsh environments. The pressure ranges from +/-10.0Pa to 7500Pa are factory calibrated and have traceable calibration certificates to international standards. The display can indicate the measured values in either Pa, hPa, kPa, m/s, l/s, m³/s, m³/h or ACR (air change rate).

The principle of the control is simple. The CMR Transducer provides a stable and repeatable pressure measurement with a linearity of 0.25% and the control loop is extremely fast to control fan speeds, air valves and dampers with powerful and fast response drives and actuators. The drives can be electric or pneumatic.

CMR TRANSDUCER

The transducer is manufactured by CMR with high precision engineered components. The principle is the measurement of the displacement of the diaphragm by means of a push and pull variable reluctance circuit which is not affected by humidity and hence it can be used in any industrial or commercial environment. There are no mechanical connections to any of the sensing coils and the diaphragm.



CMR Transducer

Extremely low pressures can be measured with excellent repeatability and minimal hysteresis. The diaphragm displacement is so small that no air volume is required to measure the air pressure which means measurement tubing can be connected in excess of 200m without losing accuracy of the measurement speed.

The zero drift is minimized by the measuring copper coils which are matched to provide excellent self compensation. One coil measures positive and the other negative drift and therefore balances any excessive drift between two tolerance limits in its life cycle. The CMR Transducer has a proven field track record of over 30 years. All CMR Sensors are temperature compensated in a computerised climate chamber.



CMR Climate Chamber

CONTROL OUTPUT

The DPC510 can drive all fast and slow moving actuators such as synchronous motors with drive open-stop-close action or industry standard actuators with control inputs and feedbacks of 0..10V and 4..20mA. Because of the high speed and resolution of the sensor and control loop, the controller is capable of driving the actuators to the required position precisely and without hunting.

AUTO CONTROL SET POINT AND FEED BACK

A main set point and a secondary set point i.e. night set back can be adjusted via the keyboard. External set points can be transmitted by analog 0..10V and 4..20mA or digitally via Modbus communication from a central BMS. The actual control value is continuously monitored. This value is available as 0..10V signal to the BMS, remote LCD display and on the modbus network.

HAND-AUTO CONTROL

A Hand-Auto keyboard control button is provided. When selecting the Hand option, the actuators actual position is written into memory and hence the actuator shall not run away. By pressing the up or down key, the set point of the hand output to the actuator or speed controller can be adjusted to any position. This is ideal for commissioning or emergency actions. The actual position of the actuators or fan speeds are continuously monitored and is expressed as 0..10V to the BMS or remote display. It is also on the modbus network.

ACTUATORS AND DAMPERS

The DPC510 can control almost any range of dampers or fan speed controls with a variety of actuation times from 1s up 400s without hunting. It is recommended to use CMR approved actuators and dampers as the mechanical strength of the actuator drive shaft is critical when operating at very high speeds. The DPC is compatible with all industrial and commercial actuators. The internal power supply of the DPC can drive actuators up to 48VA at 24Vac. Larger drives need an external power supply.

POWER SUPPLY

The DPC510 has a built in isolation transformer complete with a main fuse therefore eliminating additional power supplies on site. It can be supplied in 24Vac, 110Vac and 230Vac and has a flying lead for easy connection on site.

ENCLOSURES

The DPC510 enclosures are wall mount and supplied with a perspex front lid. A keylock is available. When the lid is fitted, the enclosure has a protection class of IP65. The front control panel is a custom made keyboard and LCD display. The cable glands are fitted and sealed. Two sets of the transducer tube connections are fitted and consists of chromed brass nipples identified as red for positive and blue for negative pressure connections.

DPC-510 PRESSURE VOLUME CONTROL

Three Typical Constant Supply Air Volume and Room Pressure Extract Control methods

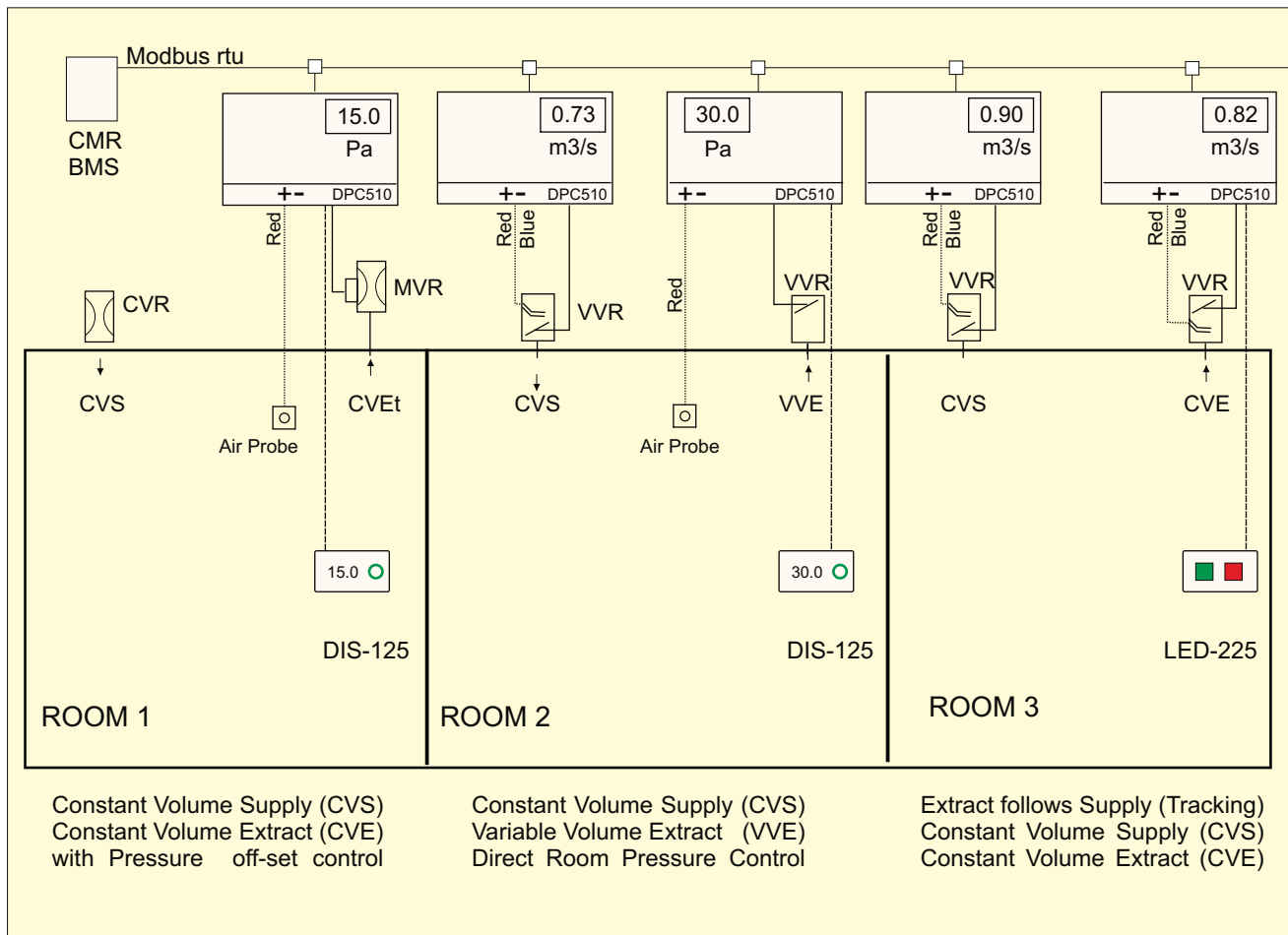

ROOM 1 Supply and Extract

Room 1 has a mechanical constant volume supply valve CVR which provides an accurate volume regardless of the static pressure changes in the duct. It is factory calibrated. The extract has a motorised constant volume valve MVR, which is similar to the CVR but the volume can be changed from remote. The room pressure is measured by the extract DPC and it controls the MVR by changing the set point to achieve 15Pa. The CVR and MVR cannot be shut off. A remote display of the room pressure and alarm is connected to the extract DPC.

ROOM 2 Supply

Room 2 has a VVR valve on the supply duct. The DPC measures the air volume in the VVR and controls a constant air change rate into the room.

ROOM 2 Extract

Room 2 has a VVR valve on the extract duct. The pressure sensor measures the room pressure against a reference and controls the actuator on the extract VVR directly to maintain a room pressure of 30 Pa. A remote Display and Alarm is connected to the extract DPC.

ROOM 3 Supply and Extract

The supply and extract VVRs are controlled having both constant volume control. The extract follows the supply in volume which is done via the modbus network and is called 'Volume Tracking'. An off set can be adjusted in the DPC-510 to have either more or less extract in the room. A remote LED alarm plate is fitted indicating with red or green lights the alarm status.



DPC-510 Controller



Air Probe



Tubes + Fittings



DIS-125 LED-225



VVR Valve



CVR Valve

DPC-510 AIR CONTROL APPLICATIONS

TYPICAL TEST CHAMBER CONTROL - POSITIVE - NEGATIVE AND VOLUME TRACKING WITH THE DPC-510

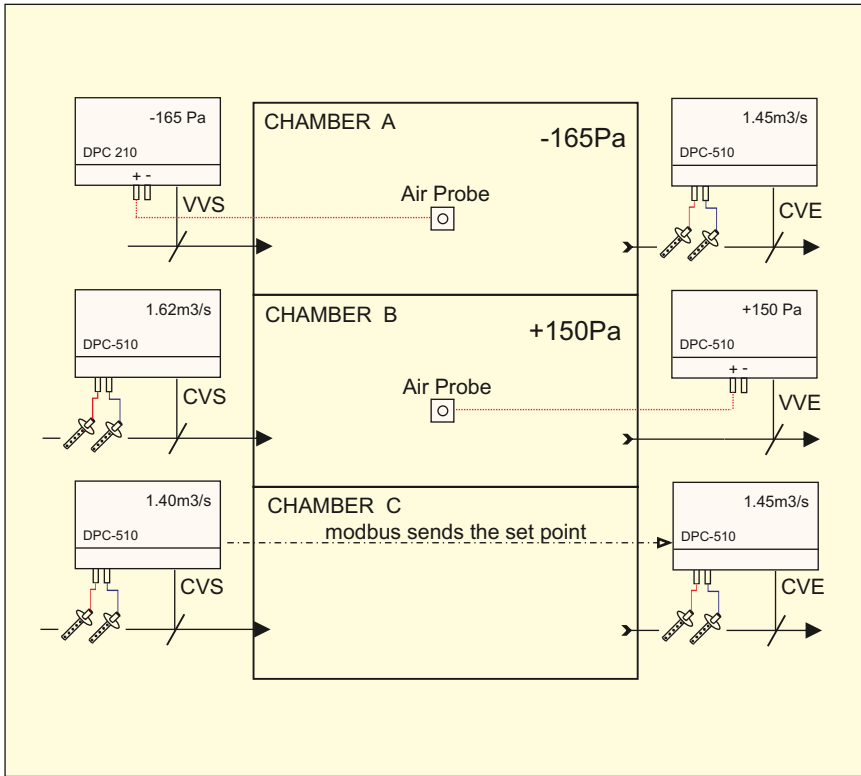

DPC510 CONFIGURATION

CHAMBER A
The extract is configured as constant volume extract (CVE) to maintain 1.45m³/s. The supply air is set up to be variable volume supply (VVS). The chamber pressure is measured via the air probe and the supply damper is controlled to maintain -165Pa in the chamber.

CHAMBER B
The supply air is configured to be a constant volume supply (CVS) to maintain 1.62m³/s. The extract is set up as variable volume extract (VVE). The chamber pressure is measured via the air probe and the extract damper is controlled to maintain +150Pa in the chamber.

CHAMBER C
The supply is configured as constant volume supply (CVS) master and the extract is configured as constant volume extract (CVE) slave with more extract. The extract or supply damper volume can be off-set in the DPC to have the room positive or negative. (Tracking with off-set)

The above schematic shows typical applications for the DPC controllers. The DPC is used for process and heavy duty industrial installations and they can be mounted on the valves in the field or in a central control panel, which makes calibration, maintenance and validation easier in future. Commissioning is very easy via the modbus network from remote. The CMR PVC tubing can be run up to 200m in length to any of the above constant volume venturi valves and the chamber pressure air duct probes. The DPC is a standard controller which can be configured to provide constant supply, constant extract, variable volume supply or variable volume extract. It has the necessary interfaces to be set up as a tracking controller which means either supply or extract can be tracked with an adjustable off-set. All functions are easily selectable.

The CMR dampers and valves are fitted with CMR fast and heavy duty actuators and the mechanical connections and the gearboxes have been designed for continuous high torque and speed action. All DPCs can be connected to BMS, SCADA or PLC computer systems to read in the pressures, volumes and feedbacks and write set points, night set backs etc. In case of BMS computer failure, the DPC reverts back to its default set points, a vital advantage in critical manufacturing processes. All DPCs have control freeze and timed release when chamber doors are opened and closed. The DPC is supplied with traceable calibration certificates to International Standards and site certification can be carried out by CMR. In fact CMR provides a complete commissioning and site calibration service.

TYPICAL STATIC PRESSURE AND CONSTANT FAN SPEED AND VOLUME DAMPER CONTROL APPLICATIONS

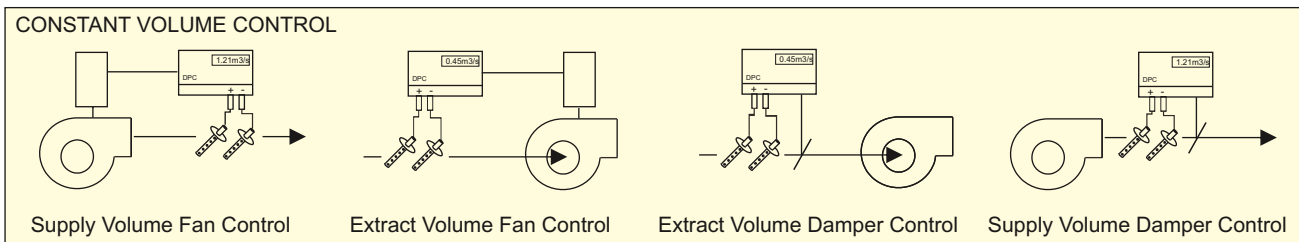
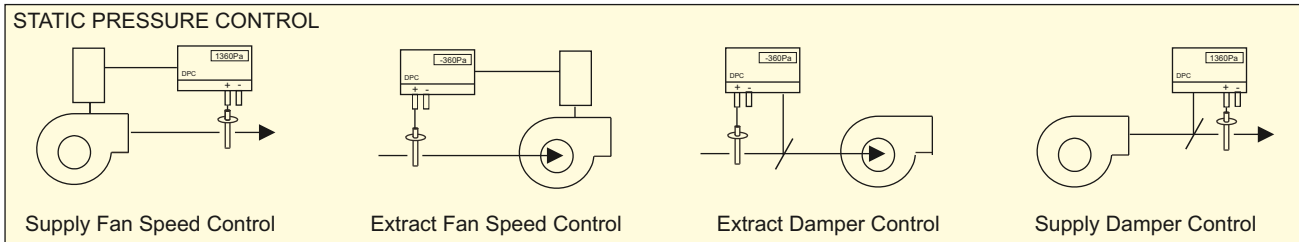

DPC-510 DAMPER CONTROL METHODS

INDUSTRIAL TEST CHAMBER AIR PRESSURE - AIR VOLUME DAMPER CONTROLS WITH A DPC-510

Mode 'A'

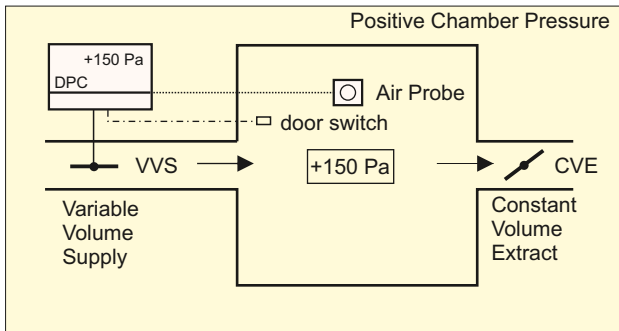

The chamber must be controlled at +150Pa positive pressure using variable volume supply and constant extract. On start up, the supply damper must be open and starts closing if the pressure is greater than 150Pa. The damper motor stops when a door is opened and re-starts after a time out when closed again.

Mode 'B'

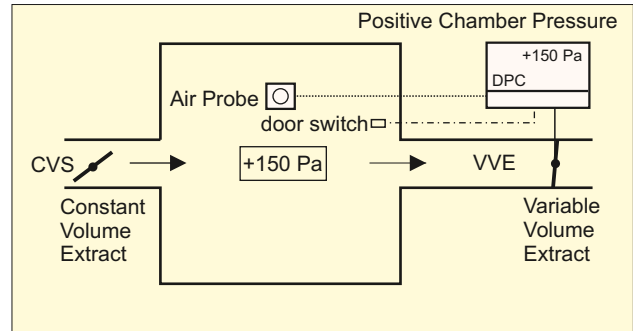

The chamber must be controlled at +150Pa positive pressure using variable volume extract and constant supply. On start up, the extract damper must be closed and starts opening up if the pressure is greater than +150Pa. The damper motor stops when a door is opened and re-starts after a time out when closed again.

Mode 'C'

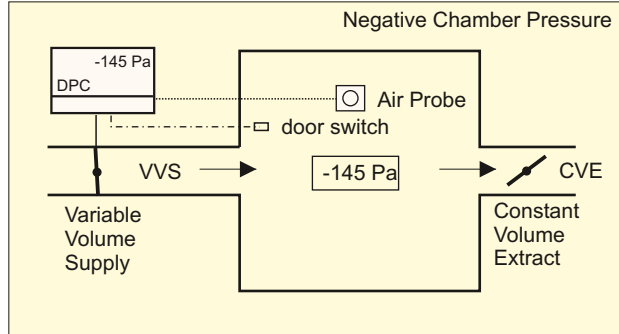

The chamber must be controlled at -145Pa negative pressure using variable volume supply and constant extract. On start up, the supply damper must be closed and starts opening if the pressure is more negative than -145Pa. The damper motor stops when a door is opened and re-starts after a time out when closed again.

Mode 'D'

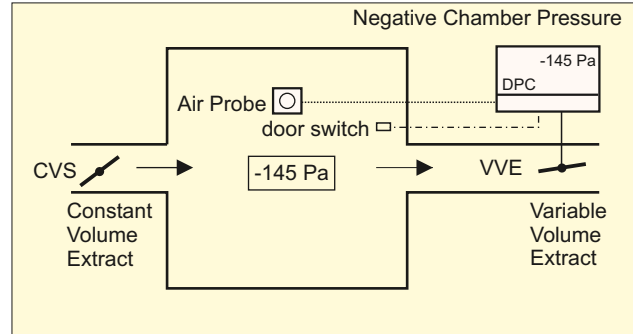

The chamber must be controlled at -145Pa negative pressure using variable volume extract and constant supply. On start up, the extract damper must be open and starts closing if the pressure is more negative than -145Pa. The damper motor stops when a door is opened and re-starts after a time out when closed again.

Mode 'E'

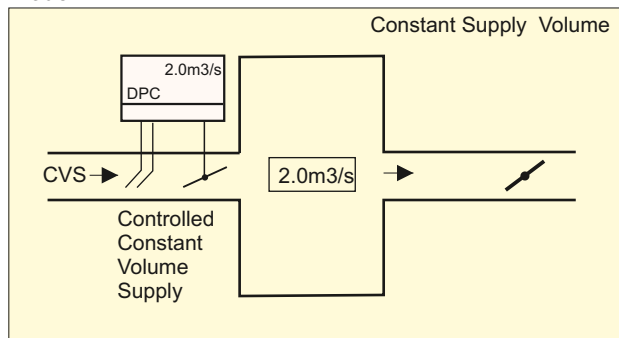

The chamber must be controlled at 2.0m³/s constant supply volume. On start up, the supply damper must be open and if the volume is more than the set point the damper starts closing to achieve the required constant volume. The controller has an adjustable set point to vary the supply at any time. The DPC can be linked to an extract DPC controller if fitted to provide supply to extract tracking.

Mode 'F'

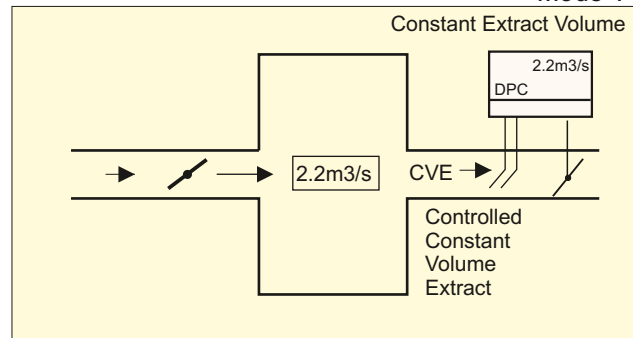

The chamber must be controlled at 2.2m³/s constant extract volume. On start up, the extract damper must be open and if the volume is more than the set point the damper starts closing to achieve the required constant volume. The controller has an adjustable set point to vary the extract at any time. The DPC can be linked to a supply DPC controller if fitted to provide extract to supply tracking.

DPC-510 FAN SPEED CONTROL METHODS

INDUSTRIAL TEST CHAMBER AIR PRESSURE - AIR VOLUME FAN SPEED CONTROL WITH A DPC-510

Mode 'G'

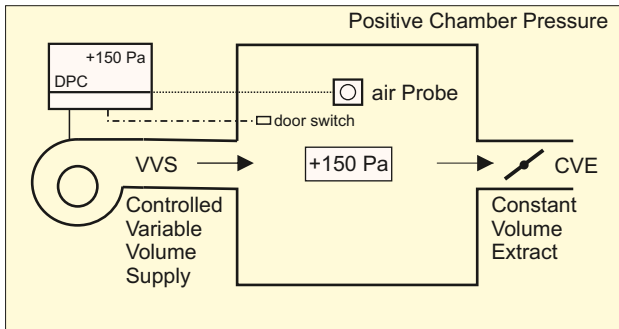

The chamber must be controlled at +150Pa positive pressure using variable volume supply and constant extract. On start up, the supply fan must speed up and starts reducing speed if the chamber pressure is greater than +150Pa. The fan speed locks when a door is opened and re-starts after a time out when closed again.

Mode 'H'

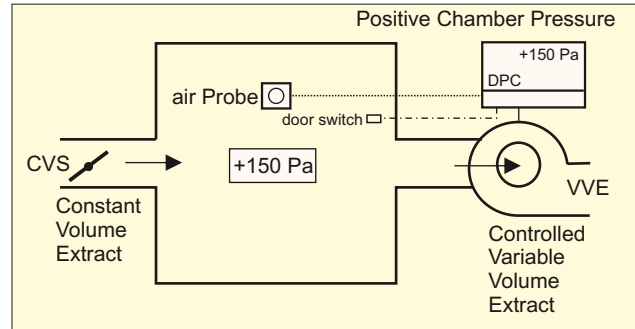

The chamber must be controlled at +150Pa positive pressure using variable volume extract and constant supply. On start up, the extract fan must reduce and starts speeding up if the chamber pressure is greater than +150Pa. The fan speed locks when a door is opened and re-starts after a time out when closed again.

Mode 'J'

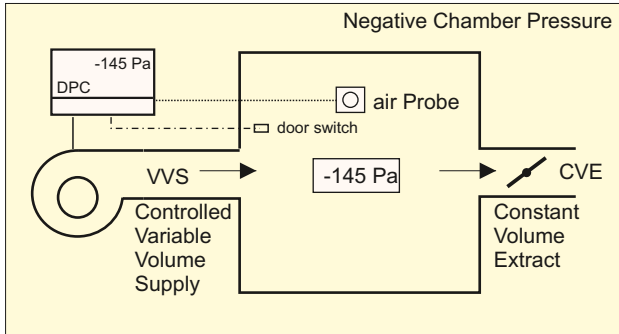

The chamber must be controlled at -145Pa negative pressure using variable volume supply and manual extract. On start up, the supply fan must reduce speed and starts speeding up if the pressure is more negative than -145Pa. The fan speed locks when a door is opened and re-starts after a time out when closed again.

Mode 'K'

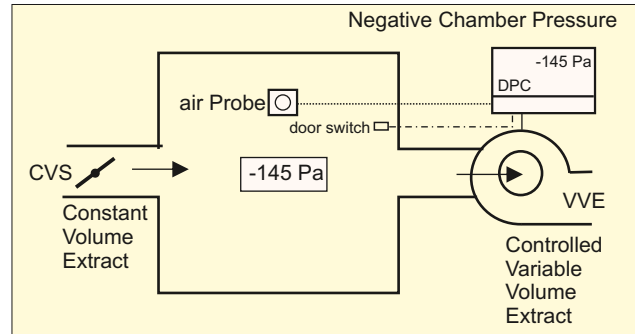

The chamber must be controlled at -145Pa negative pressure using variable volume extract and constant supply. On start up, the extract fan must speed up and starts reducing speed if the pressure is more negative than -145Pa. The fan speed locks when a door is opened and re-starts after a time out when closed again.

Mode 'L'

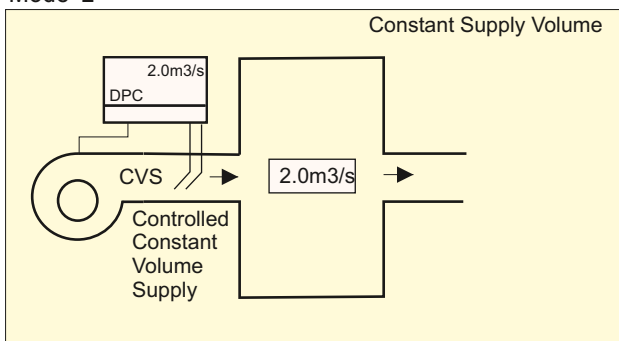

The chamber must be controlled at 2.0m³/s constant volume supply. On start up, the supply fan must speed up and if the volume is more than the set point the fan speed starts reducing to achieve the required constant volume. The controller has an adjustable set point to vary the supply volume if required. The DPC can be linked to the extract fan to provide supply to extract tracking.

Mode 'M'

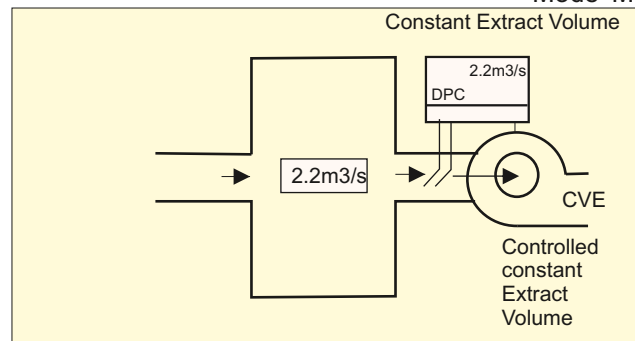

The chamber must be controlled at 2.2m³/s constant extract volume. On start up, the extract fan must speed up and if the volume is more than the set point the fan speed starts reducing to achieve the required constant volume. The controller has an adjustable set point to vary the extract volume if required. The DPCs can be linked to the supply fan to provide extract to supply tracking.

DPC-510 PRESSURE VOLUME CONTROL

CONTROL VALUE LCD

This LCD display indicates the actual Room Pressure.

CONTROL SET POINT

The control set point of the Room Pressure is set to 45.0 Pa. The set point is displayed in the lower left corner.

LOW PRESSURE ALARM

The low alarm set point can be set to 40 Pa. If the Pressure is lower than 40.0 Pa then it shall alarm after a time out. The internal timer is adjustable from 1 - 300s which means the alarm buzzer and light switches on after i.e. 20 seconds after the pressure is lower than 40.0 Pa

LOW VOLUME ALARM

The air volume is monitored and shall control the extract damper to limit the volume in case of total door opening of the room. The volume is too low or too high and alarm can be raised.

MUTE ALARM

The BELL button is the mute button and by pressing it the buzzer shall switch off.

The alarm can be permanently muted via the parameter set up which is password protected.

CALIBRATION MODE

If the CALIBRATION mode is switched to ON the damper motor stops operating and the damper position is locked in the last position. The tubes can now be removed from the velocity sensor and calibration work can be carried out safely.

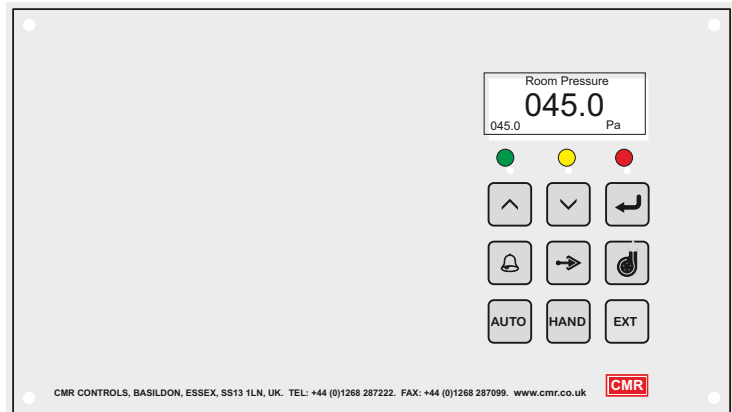

DPC-510 Controller Front Panel

AUTO OPERATION

The AUTO switch shall switch the DPC controller into automatic control if it was switched to HAND. Which means the damper motor works on room pressure or volume control.

HAND OPERATION

If the switch is set to HAND position, the damper motor or Fan Speed Controllers can be positioned with the UP and DOWN arrow keys which program the manual set point to any position from fully closed at 0% to fully open at 100%.

FAN BUTTON

This is an optional switch to power up a ventilator

PROGRAM BUTTON

This is used to enter the parameters into the controller and is password protected.

ALL HEALTHY

The green light is normally on if there are no alarms present. I.e. the pressure or air volume is normal and there is no other alarm present.

MUTE ALARM

By pressing the BELL button the alarm can be muted.

AUTO - HAND

When the AUTO button is pressed it shall go into automatic mode. When the HAND button is pressed the damper position can be set to any fixed position. The LCD indicates 'hand'

GRAPHIC LCD DISPLAY

The LCD display indicates the actual Room Pressure or Air Volume. The indicator is duplicated from the DPC controller Actual pressure indicator is scaled in Pa. The display is slower to indicate than the control action as dampening is programmed into the LCD.

ALARM

The red Alarm Light shall come on in case of pressure or air volume is either higher or lower than the alarm set points. The buzzer shall come on as well if not permanently muted. When pressing the BELL button the buzzer can be muted and also reset if the alarm has been set to latching.

EXT

The EXT can switch in the external set point from a device i.e. BMS etc..

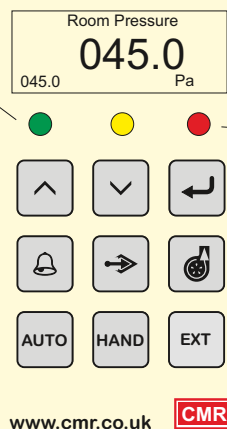

DPC-510 Issue 2

BMS wiring from DPC to BMS (20 core shielded cable 0.5mm2)
Modbus rtu Belden 8102

POSITION
045.0
045.0 %

L Power Input	N Power Input	PE Earth	0-10V scaled damper motor position out put	COM relay 1 Lamps	NO relay 1	NC relay 1	COM relay 2 Buzzer	NO relay 2	NC relay 2	COM relay 3 Volt Free Contact	NO relay 3 Volt Free Contact	NC relay 3 Volt Free Contact	0-10V actual sensor value output sensor 1	0-10V actual sensor value output sensor 2	Gnd	0-10V External Set Point input	D11 switch in external set point to T2	D12 switch in hand operation to T2	GND	MOD D1 modbus rtu 1	MOD D0 modbus rtu 1
1	3	5	20	28	29	30	31	32	33	34	35	36	41	42	45	46	48	50	56	57	58

24/110/230Vac 30VA

0 VAC

PE Earth

0-10V scaled damper motor position

COM alarm relay

NO alarm relay

NC alarm relay

COM alarm relay

NO alarm relay

NC alarm relay

COM alarm relay

NO alarm relay

NC alarm relay

COM alarm relay

NO alarm relay

NC alarm relay

0-10V Sensor 1 measured value

0-10V Sensor 2 measured value

GND Ground (-) for all in- and outputs

0-10V Set point for auto and hand control

D11 to GND T45 switch in external set point

D12 to GND T45 switch in hand operation

GND

MODBUS rtu D1

MODBUS rtu D0

T46 + Input 0-10V set point from BMS - T45 is GND
T48 to switch to GND T45 BMS to provide Volt Free Contact to switch in BMS set point on
T50 to switch to GND T45 BMS to provide Volt Free Contact to switch the DPC in Hand Mode.
When in hand mode - the set point from the BMS on T46 becomes the set point for the motor position

T20 + Output 0-10V scaled damper position feedback to BMS - T45 is GND
T41 + Input 0-10V from external sensor measured value - T45 is GND
T42 + Output 0-10V sensor scaled measured value - T45 is GND

T28 com relay 1 connection for digital input to BMS
T29 NO relay 1 connection for GND of digital input channel of BMS
T30 NC relay 1 connection for GND of digital input channel of BMS

T31 com relay 2 connection for digital input to BMS
T32 NO relay 2 connection for GND of digital input channel of BMS
T33 NC relay 2 connection for GND of digital input channel of BMS

T34 com relay 3 connection for digital input to BMS
T35 NO relay 3 connection for GND of digital input channel of BMS
T36 NC relay 3 connection for GND of digital input channel of BMS

T56 GND modbus rtu Wiring Belden 8102
T57 D1 modbus rtu
T58 D0 modbus rtu

DPC-510 0(2)..10V - 4..20mA ACTUATOR

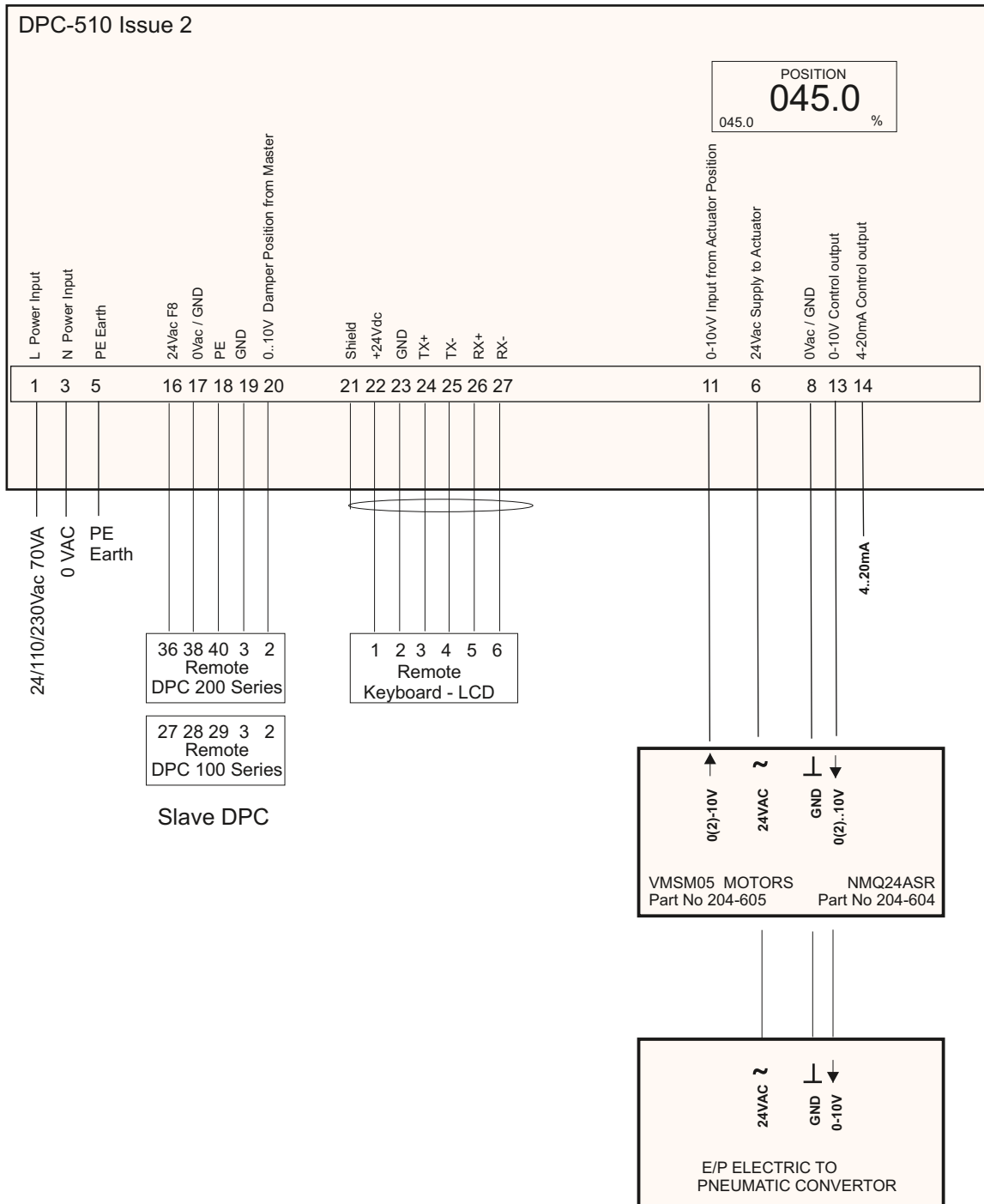

Above Drives have no limit switches must be ordered separately.

DPC-510 24VAC TRI-STATE ACTUATORS

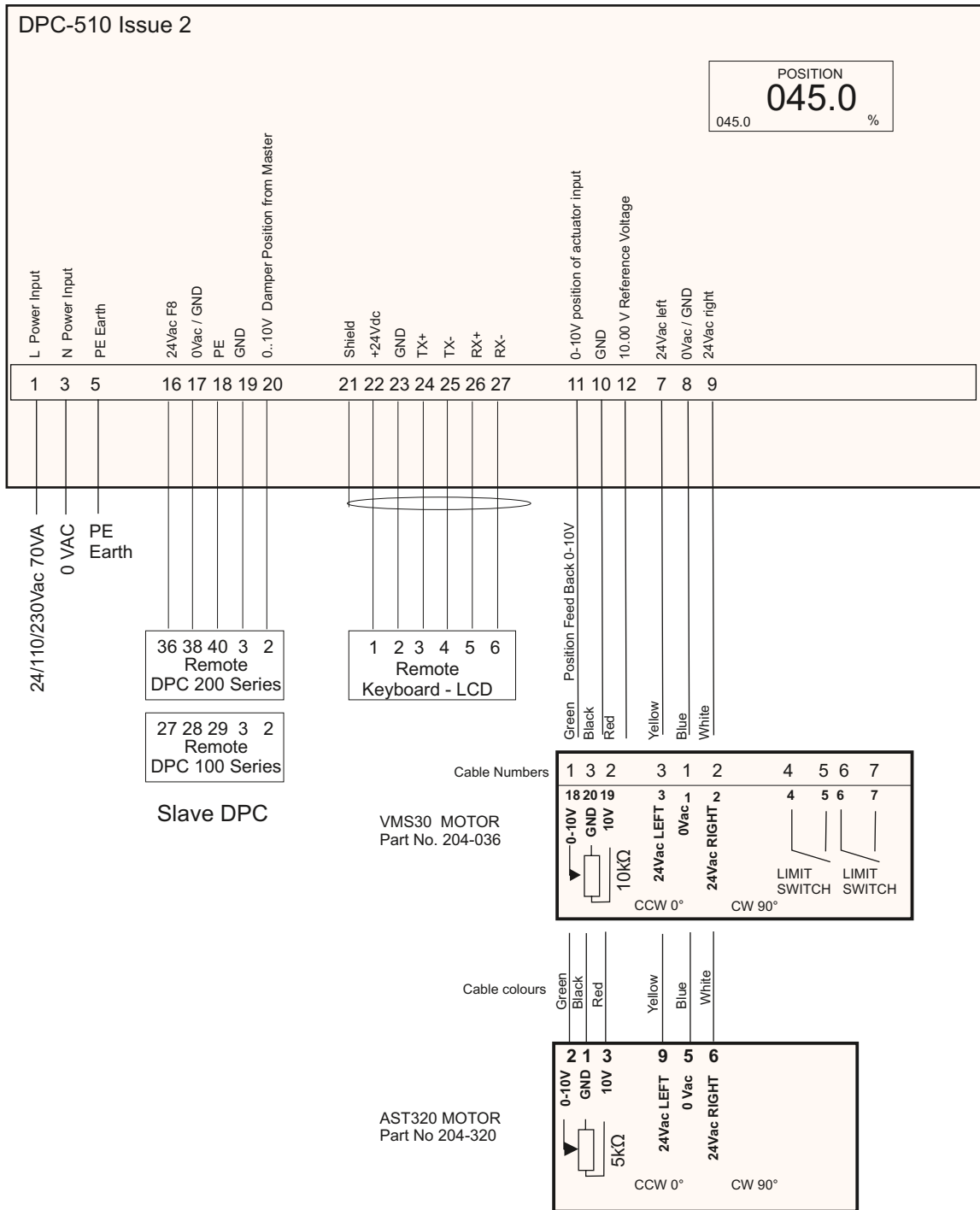

All limit switches must be adjusted to switch off motor on both sides.

DPC-510

ORDER DESCRIPTION

GENERAL

CMR manufactures the DPC-510 wall mount air pressure and air volume controller to suit many applications. Because of the variety of functions and power supplies it has been necessary to design an easy to use selection table for anybody to make up a DPC-510 controller specification to satisfy a requirement. You will find all specifications available with the associated ordering Code on the DPC-510 Controller Selection Table (Page 11). In order to select the correct part we have made up a sample selection below:

DPC-510 PART NUMBER

The DPC-510 Part Number starts with the selection of the controller type '80'.

DPC-510 Board Issue No.

The DPC-510 will have an update on the electronic board from time to time and to identify the issue No i.e. for software and hardware, this number might change. For Issue 2 the Code is '2'. The Part Number extends to '802'.

TUBE NIPPLES

The DPC-510 is normally supplied with 6 mm barbed tube nipples.. We have selected Nipple Size 6mm which has the Code 'A'. The Part Number extends to '802A'.

NEGATIVE PRESSURE RANGE

The Negative Range is specified as (-)Pa. If the application requires to measure a negative pressure against a reference, i.e. a room has to be at negative pressure compared with the corridor then the room has to be connected to the Red or (+) nipple. The blue (-) nipple shall be connected to the reference in this case the corridor. The negative room pressure shall suck on the red (+) nipple and the DPC produces an output signal equivalent of the negative pressure measured. If the DPC-510 must only measure in the positive Range i.e 0..25Pa then the Negative Range will always be selected as 0 Pa. The same applies if the measurement is in velocity pressure and needs to be square rooted. The Code is always '0000'. In the Example we have chosen - 25 Pa which has the Code '0025'.

The Part Number extends to '80 2A 0025'.

BASE TRANSDUCER MEASUREMENT RANGE

The DPC-510 Part Number incorporates a transducer range which always has the Code 'P' for manufacturing identification only.

The Part Number extends to '80 2A 0025 P'.

POSITIVE PRESSURE RANGE

If the negative range has been selected to be -25Pa then it is suggested to use +25 Pa as the Positive Pressure Range. Note that 0 Pa Pressure is now in the middle of the Sensor Range. This means the DPC can measure from -25 Pa to 0 and 0 to +25 Pa.

In the example we have chosen Positive Range +25 Pa which has the Code '0025'.

The Part Number extends to '80 2A 0025 P 0025'.

UNITS OF MEASUREMENT FOR SENSOR 1

The measurement units are expressed in Pa (Pascals) The code is 'P'. We have chosen Mode 'P'. The Part Number extends to '80 2A 0025 P 0025 P'.

CABLE GLANDS

The DPC-510 is supplied with Glands so that the motor cable, remote display plate and communication can easily be installed by an electrician to be terminated on terminals.

We have selected Glands which has the Code '0'. The Part Number extends to '80 2A 0025 P 0025 P 0'.

POWER SUPPLY

The DPC-510 can be ordered in
24VAC with Code '3'
110VAC with Code '4'
230VAC no power cable fitted with Code '5'
230 UK complete with cable and UK plug with Code '6'
230 EU complete with cable and European plug with Code '7'

All cables are 3 m long .

We have chosen 230V with cable and UK plug which has Code '6'. The Part Number extends to '80 2A 0025 P 0025 P 0 6'.

FINAL PART NUMBER

The Part Number to order is '802A 0025 P 0025 P 0 6'.

Now try and select your own DPC-510 using the DPC-510 Order Selection Table.

DPC-510

ORDER SELECTION TABLE

The Selection Table has been prepared to make ordering easy. Each column contains a number of different options which are available and a Part Number can be established depending on a specific requirement.

The Example Part Number 802A0025P0025P06 which is printed above the Selection Table and identified as being a DPC-510 with ABS enclosure, having an LCD Display and Keyboard, with an issue No 1, with 6mm barbed tube connectors, Sensor Negative Pressure Range of -25 Pa, Range Units in Pa (Pascals) and Sensor Positive Pressure Range of +25 Pa, Range Units in 'P' Pa with Cable Entry Glands, the Power Supply is an isolated 230Vac with a UK Plug.

The DPC-510 would be supplied with an LCD-Display-Keyboard mounted into the recess of the case and the measured Units are Pa (Pascals). The Decimal Point is user adjustable to 1 on the keyboard which indicates from -25..25.0 Pa. It comes standard with a traceable calibration certificate to international Standards (UKAS).

EXAMPLE PART NUMBER SELECTION (The code after the (=) sign is used i.e. 6mm = A)

80	2	A	0025	P	0025	P	0	6
P-Sensor	ISSUE	Nipple	Negative	Range	Positive	Label	Cable	Power
Part No.	No	Size	Range	Units	Range	Units	Entry	Supply
Base = 80	Issue = 2	6mm = A	0000	Pa = P	0000	Pa = P	Gland = 0	24 Vac = 3
		4mm = B	0010		0010	m/s = V		110 Vac = 4
			0025		0025	m/s = V		230 Vac = 5
			0030		0030	m3/s = Q		230UK = 6
			0050		0050	m3/h = M		230EU = 7
			0060		0060	l/s = L		
			0100		0100			
			0120		0120			
			0125		0125			
			0150		0150			
			0200		0200			
			0250		0250			
			0500		0500			
			0800		0800			
			1000		1000			
			1250		1250			
			1500		1500			
			2000		2000			
			2500		2500			
			5000		5000			
			8000		8000			

HOW TO ORDER

--	--	--	--	--	--	--	--	--

EXAMPLE

A wall mount pressure air volume controller is required of the Type DPC-510
 The latest Issue main board is required
 The tube connections must be 6mm for CMR PVC Tube.
 The Negative pressure range of the Sensor must be -100 Pa
 The Range Units are in Pa
 The Positive pressure range of sensor must be +100Pa
 The Label Units of the sensor must in be Pa.
 The Cable Entry must be Glands
 The power supply must be 24Vac

Call CMR for assistance at any time

The part Number for this DPC 210 is 80 2 A 0100 P 0100 P 0 3

CMR CONTROLS Ltd
 Precision Air Pressure and Volume Sensors

22 Repton Court Repton Close
 Basildon Essex SS13 1LN GB
 web www.cmr-controls.com

Phone +44 (0) 1268 287222
 Fax +44 (0) 1268 287099
 mail sales@cmr-controls.com



DPC-510 ISSUE 2

SPECIFICATION

Measurement Range	Sensor 1 - See order selection Table DPC-510 Page 11
Optional Range	Any Range from 25 to 7,500 Pa
Overload Capacity	Ranges 25 - 150Pa up to max 1400Pa Ranges from 200 - 7,500Pa 10 times of range
Media	Non Corrosive Gases such as Air,N ₂ ,O ₂ ,CO ₂ ,N ₂ O, inert Gases
Sensor Type	Copper Beryllium suitable for high concentration of Formaldehyde. All Stainless on request
AC Power Supplies	24 VAC 50/60Hz Fuse T1.0 A Wickmann
	110VAC 50/60Hz Fuse T315 mA Wickmann
	230VAC 50/60Hz Fuse T315 mA Wickmann
AC Control Output	24 VAC (internal power from isolation transformer) max 850mA (Fused T1A Wickmann)
DC Control Output	0..10Vdc and 4..20mA
Sensor Output Voltage RL = 5kOhm min	0-10V (0..100% of Range)
Hysteresis/Repeatability	0.1% Typical of Full Scale
Linearity (Accuracy)	0.25% of Full Scale > 100 Pa - 0.25Pa of Full Scale < 100 Pa
Zero Drift	0.02%K (+10°C to +50°C) with auto zero 0.0%
Hand - Auto Key	Digital input on T4 external set point switch T6 change over from auto to hand
External Set Point	0...10V on T2
Position Input	0...10V on T7
Alarm Threshold	On keyboard
Control Function	Off-Set - Sensitivity - Proportional Band - Timing / Integral - Ramp Speed - output Freeze
Alarm Relays	1A 24VDC / AC Low/High Alarm single pole - Buzzer and repeater single pole on-off.
Operating Temperature	+10°C to +40°C (Storage -40°C to +70°C)
Mounting Position	Vertical
Weight	1.7 kg
Electrical Connections	1 x M20mm 4 x M16mm Gland Internal screw Connections.
Air Tube Connections	2 x Positive and Negative Nipple 6.5mm O/D x 15mm long for CMR PVC Tube (4mm O/D optional)
Communication	2 x Modbus rtu - Remote Keyboard Modbus rtu
Enclosure	ABS Grey with clear front Lid - Protection Class IP65.
Conformity	EN61326-1 EMC EN61010-1 SAFETY
Calibration Certificate	CMR issues a Certificate traceable to International Standards (UKAS) as standard

