

VMS-716 PRECISION DAMPER ACTUATOR

- Heavy duty fast electric actuator
- 24VAC or DC supply to the motor
- Modulating control with input (0) 2..10V
- Position signal feed back 2..10V
- Protection class IP54
- Fitted 1m long connection cable
- Rotation adjustable from 0..95°
- Factory set to 0..90° and feed back to 2..10V
- Continuous control function
- Rotation speed 7s for 0..90°
- Torque 16Nm continuously rotating
- CMR standard 24 month warranty
- 10 Years field application experience

The VMS-716 damper actuator has been designed for commercial and industrial ventilation applications. The protection class is IP54 and it can be installed in any in-door normal environment. It is being used for the ventilation control commercial buildings, clean room pressure or constant air volume applications where a hi-speed and reliable air volume control must be achieved. It is also used in fume cupboard extract and make up air laboratory control.

It has a rotating clamp which can grip 12..26mm square damper shafts or 12..25mm round damper shafts. It will fit perfectly onto the CMR fume cupboard control valves. It will also fit directly onto the CMR square or rectangular dampers with gear drive or the round PPs chemical resistant valves and the galvanised or stainless steel valves. CMR manufactures all the associated mounting brackets also to suit specific custom applications. The motors are best used with the CMR dampers as the rotating shaft and gear mechanism on the damper must be able to withstand very fast small open and closed commands under automatic control.

The actuator has a digital motor control which has the advantage that it has a direction switch to drive clock- or anti clock wise. The actuator has built in overload control and the motor is capable driving against a block without end switches. The rotation angle can be adjusted via mechanical end stops for opening and closing.

There is an optional rotating position indicator which is part of the clamp and a red arrow can be adjusted to show the actual position. It is highly visible at a distance. A feed back is standard which is 2..10V.

A manual push button clutch mechanism can be operated by hand. When pushing the manual button, it disengages the gear drive to the application. The clamp can then be rotated manually to any position. The power should be isolated before using the manual push button as otherwise the motor drives back to the control position when the button is released. This function should only be used in a controlled maintenance condition.

When there is a power failure, the motor shall remain in its last position. It has no fail safe spring return action. The electronic is built into the actuator and there are no further adjustments to be made. Once the motor has been commissioned it will be set for life and is maintenance free.

A 1m long cable is factory fitted and can be terminated according to a wiring diagram which is on a label fixed to the actuator. The damper motor is factory tested and pre-set to a standard operation.



CMR VMS-716 Damper Actuator



CMR Damper with VMS-716 Actuator



DPC Volume valve with VMS-716 Actuator

VMS-716 ACTUATOR SPECIFICATION



VMS-716 Part No. 204-610

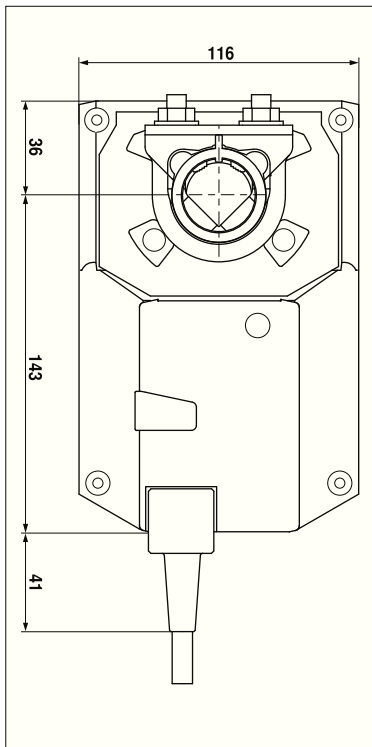

CMR Technical Data Electric Actuator Type VMS-716 Part No. 204-610	
Characteristic	Specifications
Nominal voltage	24 V ac 50/60 Hz 19.2...28.8 V 24 V dc 21.6...28.8 V
Protection class	IP54 in any position - NEMA 2, UL Enclosure Type 2
Power Consumption	13.0 W at rest 2W (For wire sizing 20VA (I max.20A @5ms)
Transformer Sizing	20.0 VA
Max output torque	16 Nm at nominal voltage
Rotation direction	Reversible with switch 0/1 - motion at Y = 0V CW or CCW
Angle of rotation	Max.95° can be limited at both ends with mechanical stops
Manual adjustment	With Hand push button disengaging of gears,can be locked
Drive shaft Clamp	◇ 12..26.7mm square ⌀ 12..25mm round damper shaft
Running time	7 seconds for 90° during normal operation
Feedback	2..10V dc standard - position accuracy 5%
Control signal Y	0..10V - operating range 2..10V
Ambient temperature	-30 to +40°C no restrictions (+50°C contact CMR)
Storage temperature	-40 to +80°C
Mode of Operation	Type 1 - Control Pollution degree 3
Certification	Certified to IEC/EN 60730-1 and IEC/EN 60730-2-14
EMC	CE according to 2004/108/EC rated impulse voltage 0.8kV
Connection Cable	1m length , 4 x 0,75 mm ²
Weight	approx. 0.8 kg
Maintenance	Maintenance free
Wiring schematics VMS-716 Actuator Part No: 204-610 Speed 4s at 8Nm Y = 0..10V Operating from 2..10V Modulating U = 2..10V Position Feed Back	<p>Cable colours: 1 = black 2 = red 3 = white 5 = orange</p>

Square or Round Shaft Adaptor				
Damper spindle	Length	○ I	■ I	◇ I
	≥52	12 ... 26.7	≥12	≤25.5
	≥20	12 ... 26.7	≥12	≤25.5