

# VGS VELOGRID

# AIR VOLUME SENSOR

- Accurate average air volume measurement
- Multiple differential pressure sensing points
- Average static and impact pressure
- BI - directional volume measurement
- Ultra-low velocity detection
- Frame made of stainless steel metal
- Standard mounting flange 30 mm
- Height manufactured in 100 mm increments
- Width manufactured in 50 mm increments
- Works with all CMR transmitters and controllers
- CMR standard 24 month warranty
- 35 years field application experience



VGS VELOGRID

The VGS Velogrid has been designed to measure air volume in ventilation ducts. The Velogrid consists of a stainless steel duct section with a length of 300 mm and is available with a 30 mm flange duct connection to suit standard stainless steel duct work.

The CMR Veloprobes made of stainless steel are fitted across the internal duct frame area in predefined spacing. Each Veloprobe has a number of pressure inlet points to measure the impact and static pressure at the same time. Both static and impact pressure ports of the Veloprobes have independent pressure manifolds which provide a smooth pressure signal of the whole measured area.

The differential pressure of both impact and static pressure is the velocity pressure which is converted by the P-Sensor to provide a total air volume measurement.

Another great advantage of the VGS Velogrid is that it can measure bi-directional as it is manufactured equally on both sides. This means the airflow is measured in one direction and should there be a reverse flow this can be detected and measured when using the CMR P-Sensor. The installation direction is therefore not important. The VGS Velogrids are manufactured in standard height increments of 100 mm going up to a maximum height of 1200 mm.

The width of the Velogrid is manufactured in increments of 50 mm up to 1200 mm. The Veloprobes are fitted across the width and are equally spaced over the height. If the duct height is 1000 mm then there will be 10 Veloprobe sets fitted into this Velogrid section.

Larger and fully welded Velogrids can be manufactured to order.

VGS VELOGRID and P-SENSOR providing accurate average air volume measurement in a duct.

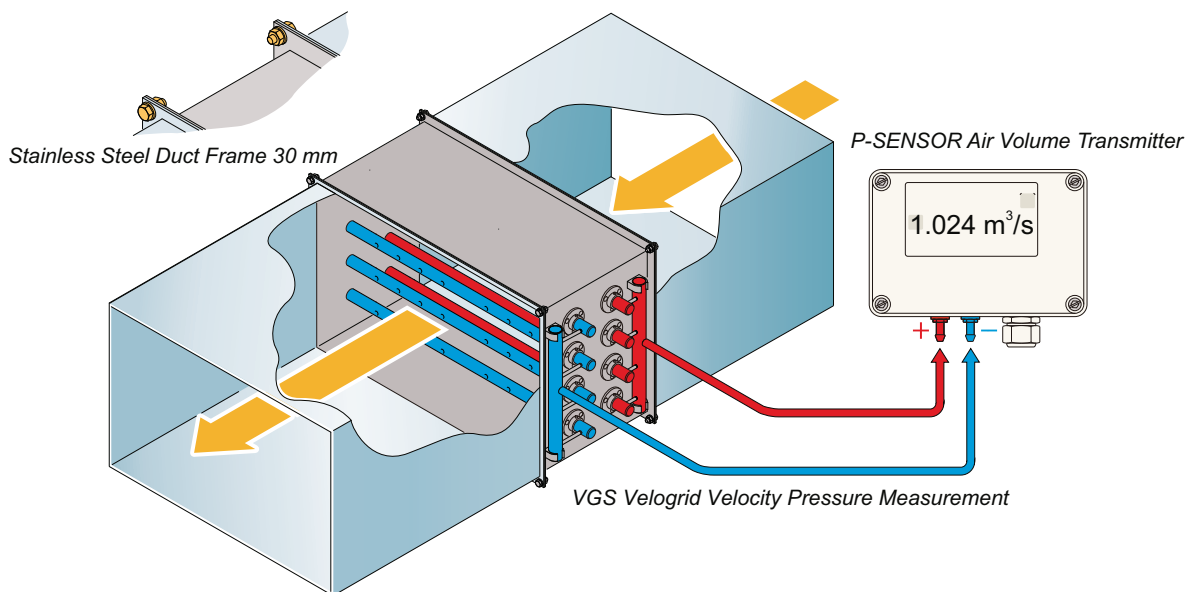

# VGS VELOGRID

The VGS Velogrid is best installed in a straight duct with a length before and after the Flowgrid. A length on the air entering the Flowgrid is more important than the air exit path.

If the air is very turbulent the CMR P-Sensor can be adjusted to provide a smoothed output signal which is a mean air volume measurement. It does not need any duct flow straighteners.

The VGS Velogrid can be installed vertically or horizontally but care must be taken that the tube connections are either on the side or at the top. Never at the bottom, as condensation might enter the measurement tubes.

The VGS Velogrid can be installed after an elbow as shown on the right. Best is to have room for a straight duct with a length before and after the Flowgrid. A length on the air entering the Flowgrid is more important than the air exit path.

If the air is very turbulent the CMR P-Sensor can be adjusted to provide a smoothed output signal which is a mean air volume measurement. It does not need any duct flow straighteners.

The VGS Velogrid can be installed vertically or horizontally but care must be taken that the tube connections are either on the side or at the top. Never at the bottom, as condensation might enter the measurement tubes.

The VGS Velogrid can be installed after a T-Section shown on the right. Best is to have room for a straight duct with a length before the Flowgrid and a length after the Flowgrid. A length on the air entering the Flowgrid is more important than the air exit path.

If the air is very turbulent the CMR P-Sensor can be adjusted to provide a smoothed output signal which is a mean air volume measurement. It does not need any duct flow straighteners.

The VGS Velogrid can be installed vertically or horizontally but care must be taken that the tube connections are either on the side or at the top. Never at the bottom, as condensation might enter the measurement tubes.

If the duct on the right cannot be fitted with a VGS Velogrid then the bottom Flowgrid measures the total volume and the top Flowgrid measures what is left over. The difference is the volume which passes through the duct on the right. Both Flowgrids need room for a straight duct with a length before and after. A length on the air entering the Flowgrid is more important than the air exit path.

If the air is very turbulent the CMR P-Sensor can be adjusted to provide a smoothed output signal which is a mean air volume measurement. It does not need any duct flow straighteners.

The VGS Velogrid can be installed vertically or horizontally but care must be taken that the tube connections are either on the side or at the top. Never at the bottom, as condensation might enter the measurement tubes.

**Send a drawing to CMR to provide a selection and full dimensional specification of the VGS Velogrid.**

# INSTALLATION

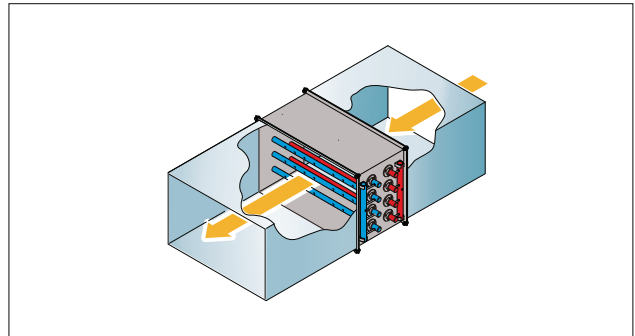

*VGS VELOGRID in a straight duct section*

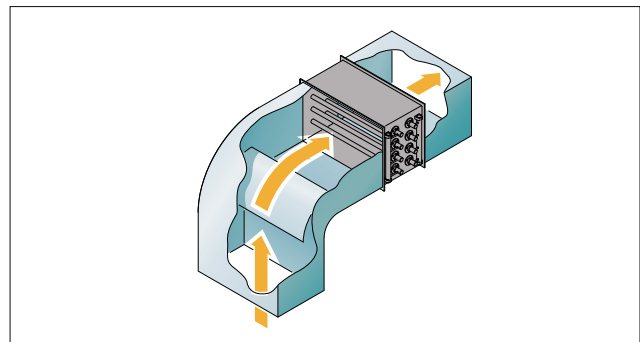

*VGS VELOGRID after an elbow duct section*

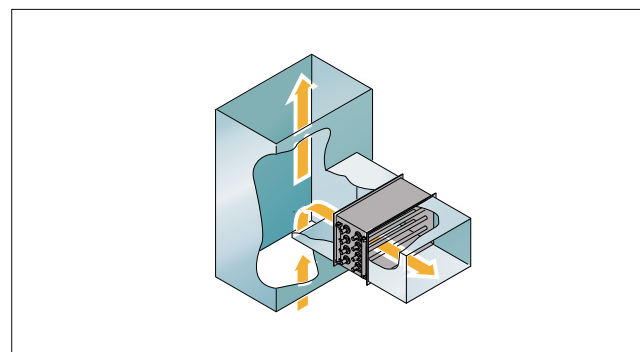

*VGS VELOGRID after a T- duct section*

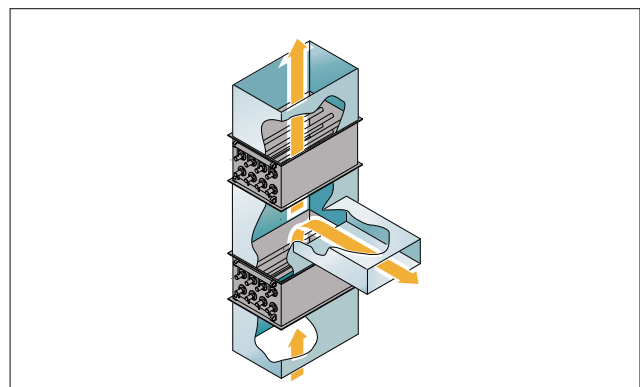

*VGS VELOGRID before and after a T-duct section*

# VGS VELOGRID VELOCITY PRESSURES

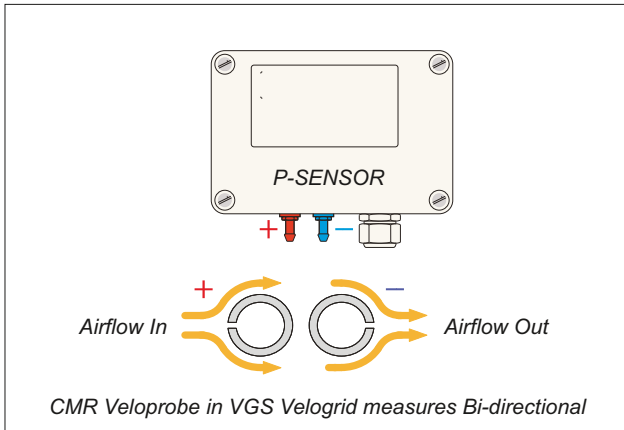

If the P-Sensor was ordered separately and not factory adjusted then it is quite simple to adjust the parameters on site.

The P-Sensor has a keyboard where the duct height and width must be entered. The magnification factor of the VGS Velogrid must be entered which is normally 2.667 if it is installed in a straight duct. If the volume indicated on the P-Sensor display is deviating from the actual measurements then the magnification factor can be adjusted to suit the installation abnormalities via the P-Sensor keyboard.

Adjust the fan to a constant volume – start with 50% of the minimum and maximum operating volume. Then take a pitot travers reading with a CAL150 or any instrument. Once the average volume has been established and it is not the same as displayed on the P-Sensor, adjust the magnification factor (mf) until the same is achieved on the display. For higher accuracy try this at 25%, 75% and 100% volume set point. The P-Sensor also has parameters to linearize the measurements for more critical applications.

Useful VGS Velogrid scaling formula:

$$\text{velocity m/s} = \sqrt{\frac{2 \times (\Delta P \text{ in Pa} / \text{mag factor})}{1.2 \text{ density}}}$$

Example:

$$2 \times (100 \text{ Pa across VGS} / 2.667 \text{ mf}) = 74.99 / 1.2 = 62.48$$

$$\sqrt{62.48} = 7.905 \text{ m/s}$$

$$7.905 \text{ m/s} \times (\text{duct height 'h' x duct width 'w'}) = \dots \text{ m}^3/\text{s} \times 3600 = \text{m}^3/\text{h}$$

The velocity pressure is measured by the Veloprobes built into the VGS Velogrid. The total impact pressure is measured on the positive (+red) and the static pressure is measured on the negative (- blue) manifold tanks. The P-Sensor shall be connected to the corresponding tanks using CMR PVC red and blue tube.

When the P-Sensor is ordered with the VGS Velogrid, then it is pre-adjusted at the factory - i.e. duct width and height, density and magnification factor (mf). The range is in m<sup>3</sup>/s, m<sup>3</sup>/h or l/s. It is ready for connection to the control or monitoring system.

Conversion table - Velocity in m/s at standard density to velocity pressure in Pa

m/s	0.0	0.1	0.2	0.3	0.4	0.5	0.6	0.7	0.8	0.9
0	0.00	0.01	0.02	0.05	0.10	0.15	0.22	0.29	0.38	0.49
1	0.60	0.73	0.86	1.01	1.18	1.35	1.54	1.73	1.94	2.17
2	2.40	2.65	2.90	3.17	3.46	3.75	4.06	4.37	4.70	5.05
3	5.40	5.77	6.14	6.53	6.94	7.35	7.78	8.21	8.66	9.13
4	9.60	10.09	10.58	11.09	11.62	12.15	12.70	13.25	13.82	14.41
5	15.00	15.61	16.22	16.85	17.50	18.15	18.82	19.49	20.18	20.89
6	21.60	22.33	23.06	23.81	24.58	25.35	26.14	26.93	27.74	28.57
7	29.40	30.25	31.10	31.97	32.86	33.75	34.66	35.57	36.50	37.45
8	38.40	39.37	40.34	41.33	42.34	43.35	44.38	45.41	46.46	47.53
9	48.60	49.69	50.78	51.89	53.02	54.15	55.30	56.45	57.62	58.81
10	60.00	61.21	62.43	63.65	64.90	66.15	67.42	68.69	69.98	71.29
11	72.60	73.93	75.26	76.61	77.98	79.35	80.74	82.13	83.54	84.97
12	86.40	87.85	89.30	90.77	92.26	93.75	95.26	96.77	98.30	99.85
13	101.40	102.97	104.54	106.23	107.74	109.35	110.98	112.61	114.26	115.93
14	117.60	119.29	120.98	122.69	124.42	126.15	127.90	129.65	131.42	133.21
15	135.00	136.81	138.62	140.45	142.30	144.15	146.02	147.89	149.78	151.69
16	153.60	155.53	157.46	159.41	161.38	163.35	165.34	167.33	169.34	171.35
17	173.40	175.45	177.50	179.57	181.66	183.75	185.86	187.97	190.10	192.25
18	194.40	196.57	198.74	200.93	203.14	205.35	207.58	209.81	212.06	214.33
19	216.60	218.89	221.18	223.49	225.82	228.15	230.50	232.85	235.22	237.61
20	240.00	242.41	244.82	247.25	249.70	252.15	254.62	257.09	259.58	262.09
21	264.60	267.13	269.66	272.21	274.78	277.35	279.94	282.53	285.14	287.77
22	290.40	293.05	295.70	298.37	301.06	303.75	306.46	309.17	311.90	314.65
23	317.40	320.17	322.94	325.73	328.54	331.35	334.18	337.01	339.86	342.73
24	345.60	348.49	351.38	354.29	357.22	360.15	363.10	366.05	369.02	372.01
25	375.00	378.01	381.02	384.05	387.10	390.15	393.22	396.29	399.38	402.49

To get the range of the P-Sensor, use the keyboard to display the range. This is the sensor range in m<sup>3</sup>/s, m<sup>3</sup>/h or l/s at 10 V / 20 mA. Enter this range into your control system. No further calculations are necessary. If you want to use the table above, use the range of the transmitter in Pa and divide it by the (mf) of the VGS. Look up the velocity above i.e. 100 Pa / 2.667 = 37.49 Pa. Look up above ~ 37.5 Pa and read on side and top ~ 8 m/s, then multiply with duct area in m<sup>2</sup> to get m<sup>3</sup>/s and multiply 3600 to get m<sup>3</sup>/h.

# VGS VELOGRID

# SPECIFICATIONS

## Selection of Velogrids

It is essential to determine the air volume during the design stage. Normally there is a minimum and a maximum volume which has to be measured.

The duct area should be calculated so that the velocity is approximately 2.5 m/s at the minimum volume and preferably 5 m/s at the operating point if possible. If the velocity is more than 5 m/s at the maximum volume then the noise level criteria needs to be considered.

The maximum velocity should not exceed 9 m/s as the duct resistance shall increase and the overall energy consumption shall go up. Use selection Table 1 to 4 on page 5 to 8.

The VGS Velogrid has the advantage that it reduces the area internally which increases the velocity pressure momentarily but will have a regain of pressure after passing over the Veloprobes. This means that the volume could go down to very low limits and still providing a reasonable velocity pressure measurement.

## Installation

The VGS Velogrid can be installed horizontally or vertically but the tube connections should be on the side or on top. It works best if it has a reasonable length of duct so that the air flow is laminar when approaching the VGS Velogrid. If a reasonable length is not available then the magnification factor (mf) can be adjusted on the P-Sensor and it can also be linearized over 10 points for unusual measuring positions. This is easily achieved by measuring the air volume at a different location of the duct and adjusting the P-Sensor via the keyboard accordingly.

## Accuracy

The VGS Velogrid can achieve a very high accuracy between minimum and maximum design volume if it is used with a P-Sensor and the linearisation function.

## Maintenance

The VGS Velogrid is maintenance free and when used in conjunction with the P-Sensor. There is no airflow going through the Veloprobes and therefore no dust particles can enter the measuring holes as they are pressurised and any particles would be deflected from the Veloprobes.

## Materials

- Frame - Stainless steel 304
- Veloprobes - Stainless steel 304
- Pipe flanges - Stainless steel 303
- Manifold tank - Stainless steel 304
- Tube nipples - Stainless steel 303
- Mounting bolts - Stainless steel 316
- Duct height 'h' from 100 mm up to 1200 mm in 100mm steps
- Duct width 'w' from 100 mm up to 1200 mm in 50 mm steps
- Duct length 300 mm
- Standard duct frame 30 mm
- Sensor/controller mounting bracket on 300 mm duct length only

## Specifications

- Recommended minimum air velocity is 2.5 m/s
- Recommended operating air velocity is 5 m/s
- Maximum recommended air velocity is 9 m/s

Very low airflow can be measured with the ultra-low P-Sensor transmitter.

Humidity 10% to 90% non condensing.

Operating temperature (dry condition) -5 to 60°C

Air density factor must be considered

VGS Velogrid Dimensions

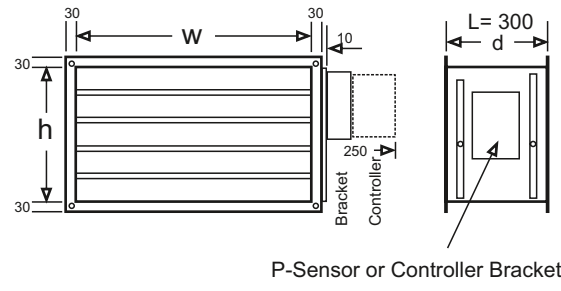

Pressure Drop

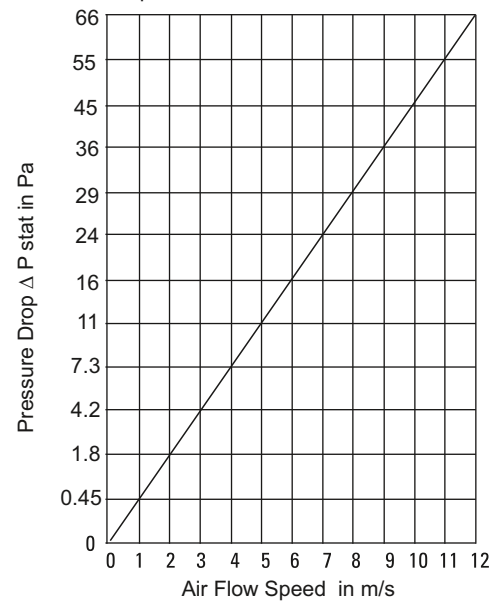

Sound Performance Level

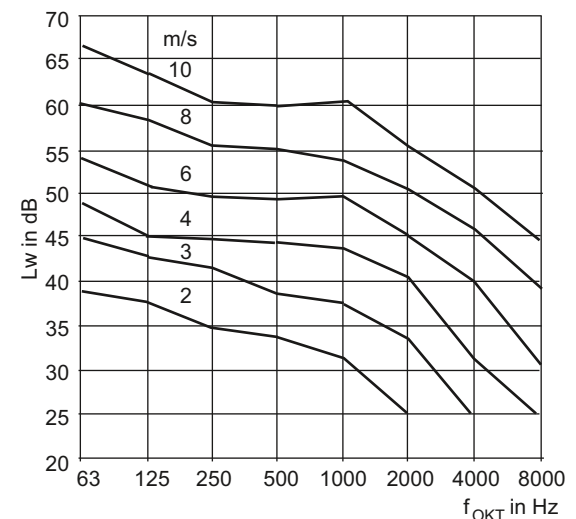

# VGS SPECIFICATIONS 30mm Flange Table 1

Part Number	Description	Height	width	depth	Area	Volume	Volume	Volume	Volume	Volume	Volume
		h	w	d		at 2 m/s	at 5 m/s	at 9 m/s	at 2 m/s	at 5 m/s	at 9 m/s
		mm	mm	mm	m2	m3/s	m3/s	m3/s	m3/h	m3/h	m3/h
VGS-0100-0200-300-30	Velogrid h x w - L=300 - Flange 30	100	200	300	0.020	0.040	0.100	0.180	144	360	648
VGS-0100-0250-300-30	Velogrid h x w - L=300 - Flange 30	100	250	300	0.025	0.050	0.125	0.225	180	450	810
VGS-0100-0300-300-30	Velogrid h x w - L=300 - Flange 30	100	300	300	0.030	0.060	0.150	0.270	216	540	972
VGS-0100-0350-300-30	Velogrid h x w - L=300 - Flange 30	100	350	300	0.035	0.070	0.175	0.315	252	630	1134
VGS-0100-0400-300-30	Velogrid h x w - L=300 - Flange 30	100	400	300	0.040	0.080	0.200	0.360	288	720	1296
VGS-0100-0450-300-30	Velogrid h x w - L=300 - Flange 30	100	450	300	0.045	0.090	0.225	0.405	324	810	1458
VGS-0100-0500-300-30	Velogrid h x w - L=300 - Flange 30	100	500	300	0.050	0.100	0.250	0.450	360	900	1620
VGS-0100-0550-300-30	Velogrid h x w - L=300 - Flange 30	100	550	300	0.055	0.110	0.275	0.495	396	990	1782
VGS-0100-0600-300-30	Velogrid h x w - L=300 - Flange 30	100	600	300	0.060	0.120	0.300	0.540	432	1080	1944
VGS-0100-0650-300-30	Velogrid h x w - L=300 - Flange 20	100	650	300	0.065	0.130	0.325	0.585	468	1170	2106
VGS-0100-0700-300-30	Velogrid h x w - L=300 - Flange 30	100	700	300	0.070	0.140	0.350	0.630	504	1260	2268
VGS-0100-0750-300-30	Velogrid h x w - L=300 - Flange 30	100	750	300	0.075	0.150	0.375	0.675	540	1350	2430
VGS-0100-0800-300-30	Velogrid h x w - L=300 - Flange 30	100	800	300	0.080	0.160	0.400	0.720	576	1440	2592
VGS-0100-0850-300-30	Velogrid h x w - L=300 - Flange 30	100	850	300	0.085	0.170	0.425	0.765	612	1530	2754
VGS-0100-0900-300-30	Velogrid h x w - L=300 - Flange 30	100	900	300	0.090	0.180	0.450	0.810	648	1620	2916
VGS-0100-0950-300-30	Velogrid h x w - L=300 - Flange 30	100	950	300	0.095	0.190	0.475	0.855	684	1710	3078
VGS-0100-1000-300-30	Velogrid h x w - L=300 - Flange 30	100	1000	300	0.100	0.200	0.500	0.900	720	1800	3240
VGS-0100-1050-300-30	Velogrid h x w - L=300 - Flange 30	100	1050	300	0.105	0.210	0.525	0.945	756	1890	3402
VGS-0100-1100-300-30	Velogrid h x w - L=300 - Flange 30	100	1100	300	0.110	0.220	0.550	0.990	792	1980	3564
VGS-0100-1150-300-30	Velogrid h x w - L=300 - Flange 30	100	1150	300	0.115	0.230	0.575	1.035	828	2070	3726
VGS-0100-1200-300-30	Velogrid h x w - L=300 - Flange 30	100	1200	300	0.120	0.240	0.600	1.080	864	2160	3888
VGS-0200-0200-300-30	Velogrid h x w - L=300 - Flange 30	200	200	300	0.040	0.080	0.200	0.360	288	720	1296
VGS-0200-0250-300-30	Velogrid h x w - L=300 - Flange 30	200	250	300	0.050	0.100	0.250	0.450	360	900	1620
VGS-0200-0300-300-30	Velogrid h x w - L=300 - Flange 30	200	300	300	0.060	0.120	0.300	0.540	432	1080	1944
VGS-0200-0350-300-30	Velogrid h x w - L=300 - Flange 30	200	350	300	0.070	0.140	0.350	0.630	504	1260	2268
VGS-0200-0400-300-30	Velogrid h x w - L=300 - Flange 30	200	400	300	0.080	0.160	0.400	0.720	576	1440	2592
VGS-0200-0450-300-30	Velogrid h x w - L=300 - Flange 30	200	450	300	0.090	0.180	0.450	0.810	648	1620	2916
VGS-0200-0500-300-30	Velogrid h x w - L=300 - Flange 30	200	500	300	0.100	0.200	0.500	0.900	720	1800	3240
VGS-0200-0550-300-30	Velogrid h x w - L=300 - Flange 30	200	550	300	0.110	0.220	0.550	0.990	792	1980	3564
VGS-0200-0600-300-30	Velogrid h x w - L=300 - Flange 30	200	600	300	0.120	0.240	0.600	1.080	864	2160	3888
VGS-0200-0650-300-30	Velogrid h x w - L=300 - Flange 30	200	650	300	0.130	0.260	0.650	1.170	936	2340	4212
VGS-0200-0700-300-30	Velogrid h x w - L=300 - Flange 30	200	700	300	0.140	0.280	0.700	1.260	1008	2520	4536
VGS-0200-0750-300-30	Velogrid h x w - L=300 - Flange 30	200	750	300	0.150	0.300	0.750	1.350	1080	2700	4860
VGS-0200-0800-300-30	Velogrid h x w - L=300 - Flange 30	200	800	300	0.160	0.320	0.800	1.440	1152	2880	5184
VGS-0200-0850-300-30	Velogrid h x w - L=300 - Flange 30	200	850	300	0.170	0.340	0.850	1.530	1224	3060	5508
VGS-0200-0900-300-30	Velogrid h x w - L=300 - Flange 30	200	900	300	0.180	0.360	0.900	1.620	1296	3240	5832
VGS-0200-0950-300-30	Velogrid h x w - L=300 - Flange 30	200	950	300	0.190	0.380	0.950	1.710	1368	3420	6156
VGS-0200-1000-300-30	Velogrid h x w - L=300 - Flange 30	200	1000	300	0.200	0.400	1.000	1.800	1440	3600	6480
VGS-0200-1050-300-30	Velogrid h x w - L=300 - Flange 30	200	1050	300	0.210	0.420	1.050	1.890	1512	3780	6804
VGS-0200-1100-300-30	Velogrid h x w - L=300 - Flange 30	200	1100	300	0.220	0.440	1.100	1.980	1584	3960	7128
VGS-0200-1150-300-30	Velogrid h x w - L=300 - Flange 30	200	1150	300	0.230	0.460	1.150	2.070	1656	4140	7452
VGS-0200-1200-300-30	Velogrid h x w - L=300 - Flange 30	200	1200	300	0.240	0.480	1.200	2.160	1728	4320	7776
VGS-0300-0200-300-30	Velogrid h x w - L=300 - Flange 30	300	200	300	0.060	0.120	0.300	0.540	432	1080	1944
VGS-0300-0250-300-30	Velogrid h x w - L=300 - Flange 30	300	250	300	0.075	0.150	0.375	0.675	540	1350	2430
VGS-0300-0300-300-30	Velogrid h x w - L=300 - Flange 30	300	300	300	0.090	0.180	0.450	0.810	648	1620	2916
VGS-0300-0350-300-30	Velogrid h x w - L=300 - Flange 30	300	350	300	0.105	0.210	0.525	0.945	756	1890	3402
VGS-0300-0400-300-30	Velogrid h x w - L=300 - Flange 30	300	400	300	0.120	0.240	0.600	1.080	864	2160	3888
VGS-0300-0450-300-30	Velogrid h x w - L=300 - Flange 30	300	450	300	0.135	0.270	0.675	1.215	972	2430	4374
VGS-0300-0500-300-30	Velogrid h x w - L=300 - Flange 30	300	500	300	0.150	0.300	0.750	1.350	1080	2700	4860
VGS-0300-0550-300-30	Velogrid h x w - L=300 - Flange 30	300	550	300	0.165	0.330	0.825	1.485	1188	2970	5346
VGS-0300-0600-300-30	Velogrid h x w - L=300 - Flange 30	300	600	300	0.180	0.360	0.900	1.620	1296	3240	5832
VGS-0300-0650-300-30	Velogrid h x w - L=300 - Flange 30	300	650	300	0.195	0.390	0.975	1.755	1404	3510	6318
VGS-0300-0700-300-30	Velogrid h x w - L=300 - Flange 30	300	700	300	0.210	0.420	1.050	1.890	1512	3780	6804
VGS-0300-0750-300-30	Velogrid h x w - L=300 - Flange 30	300	750	300	0.225	0.450	1.125	2.025	1620	4050	7290
VGS-0300-0800-300-30	Velogrid h x w - L=300 - Flange 30	300	800	300	0.240	0.480	1.200	2.160	1728	4320	7776
VGS-0300-0850-300-30	Velogrid h x w - L=300 - Flange 30	300	850	300	0.255	0.510	1.275	2.295	1836	4590	8262
VGS-0300-0900-300-30	Velogrid h x w - L=300 - Flange 30	300	900	300	0.270	0.540	1.350	2.430	1944	4860	8748
VGS-0300-0950-300-30	Velogrid h x w - L=300 - Flange 30	300	950	300	0.285	0.570	1.425	2.565	2052	5130	9234
VGS-0300-1000-300-30	Velogrid h x w - L=300 - Flange 30	300	1000	300	0.300	0.600	1.500	2.700	2160	5400	9720
VGS-0300-1050-300-30	Velogrid h x w - L=300 - Flange 30	300	1050	300	0.315	0.630	1.575	2.835	2268	5670	10206
VGS-0300-1100-300-30	Velogrid h x w - L=300 - Flange 30	300	1100	300	0.330	0.660	1.650	2.970	2376	5940	10692
VGS-0300-1150-300-30	Velogrid h x w - L=300 - Flange 30	300	1150	300	0.345	0.690	1.725	3.105	2484	6210	11178
VGS-0300-1200-300-30	Velogrid h x w - L=300 - Flange 30	300	1200	300	0.360	0.720	1.800	3.240	2592	6480	11664

# VGS SPECIFICATIONS 30mm Flange Table 2

Part Number	Description	Height	width	depth	Area	Volume	Volume	Volume	Volume	Volume	Volume
		h	w	d		at 2 m/s	at 5 m/s	at 9 m/s	at 2 m/s	at 5 m/s	at 9 m/s
		mm	mm	mm	m2	m3/s	m3/s	m3/s	m3/h	m3/h	m3/h
VGS-0400-0200-300-30	Velogrid h x w - L=300 - Flange 30	400	200	300	0.080	0.160	0.400	0.720	576	1440	2592
VGS-0400-0250-300-30	Velogrid h x w - L=300 - Flange 30	400	250	300	0.100	0.200	0.500	0.900	720	1800	3240
VGS-0400-0300-300-30	Velogrid h x w - L=300 - Flange 30	400	300	300	0.120	0.240	0.600	1.080	864	2160	3888
VGS-0400-0350-300-30	Velogrid h x w - L=300 - Flange 30	400	350	300	0.140	0.280	0.700	1.260	1008	2520	4536
VGS-0400-0400-300-30	Velogrid h x w - L=300 - Flange 30	400	400	300	0.160	0.320	0.800	1.440	1152	2880	5184
VGS-0400-0450-300-30	Velogrid h x w - L=300 - Flange 30	400	450	300	0.180	0.360	0.900	1.620	1296	3240	5832
VGS-0400-0500-300-30	Velogrid h x w - L=300 - Flange 30	400	500	300	0.200	0.400	1.000	1.800	1440	3600	6480
VGS-0400-0550-300-30	Velogrid h x w - L=300 - Flange 30	400	550	300	0.220	0.440	1.100	1.980	1584	3960	7128
VGS-0400-0600-300-30	Velogrid h x w - L=300 - Flange 30	400	600	300	0.240	0.480	1.200	2.160	1728	4320	7776
VGS-0400-0650-300-30	Velogrid h x w - L=300 - Flange 30	400	650	300	0.260	0.520	1.300	2.340	1872	4680	8424
VGS-0400-0700-300-30	Velogrid h x w - L=300 - Flange 30	400	700	300	0.280	0.560	1.400	2.520	2016	5040	9072
VGS-0400-0750-300-30	Velogrid h x w - L=300 - Flange 30	400	750	300	0.300	0.600	1.500	2.700	2160	5400	9720
VGS-0400-0800-300-30	Velogrid h x w - L=300 - Flange 30	400	800	300	0.320	0.640	1.600	2.880	2304	5760	10368
VGS-0400-0850-300-30	Velogrid h x w - L=300 - Flange 30	400	850	300	0.340	0.680	1.700	3.060	2448	6120	11016
VGS-0400-0900-300-30	Velogrid h x w - L=300 - Flange 30	400	900	300	0.360	0.720	1.800	3.240	2592	6480	11664
VGS-0400-0950-300-30	Velogrid h x w - L=300 - Flange 30	400	950	300	0.380	0.760	1.900	3.420	2736	6840	12312
VGS-0400-1000-300-30	Velogrid h x w - L=300 - Flange 30	400	1000	300	0.400	0.800	2.000	3.600	2880	7200	12960
VGS-0400-1050-300-30	Velogrid h x w - L=300 - Flange 30	400	1050	300	0.420	0.840	2.100	3.780	3024	7560	13608
VGS-0400-1100-300-30	Velogrid h x w - L=300 - Flange 30	400	1100	300	0.440	0.880	2.200	3.960	3168	7920	14256
VGS-0400-1150-300-30	Velogrid h x w - L=300 - Flange 30	400	1150	300	0.460	0.920	2.300	4.140	3312	8280	14904
VGS-0400-1200-300-30	Velogrid h x w - L=300 - Flange 30	400	1200	300	0.480	0.960	2.400	4.320	3456	8640	15552
VGS-0500-0200-300-30	Velogrid h x w - L=300 - Flange 30	500	200	300	0.100	0.200	0.500	0.900	720	1800	3240
VGS-0500-0250-300-30	Velogrid h x w - L=300 - Flange 30	500	250	300	0.125	0.250	0.625	1.125	900	2250	4050
VGS-0500-0300-300-30	Velogrid h x w - L=300 - Flange 30	500	300	300	0.150	0.300	0.750	1.350	1080	2700	4860
VGS-0500-0350-300-30	Velogrid h x w - L=300 - Flange 30	500	350	300	0.175	0.350	0.875	1.575	1260	3150	5670
VGS-0500-0400-300-30	Velogrid h x w - L=300 - Flange 30	500	400	300	0.200	0.400	1.000	1.800	1440	3600	6480
VGS-0500-0450-300-30	Velogrid h x w - L=300 - Flange 30	500	450	300	0.225	0.450	1.125	2.025	1620	4050	7290
VGS-0500-0500-300-30	Velogrid h x w - L=300 - Flange 30	500	500	300	0.250	0.500	1.250	2.250	1800	4500	8100
VGS-0500-0550-300-30	Velogrid h x w - L=300 - Flange 30	500	550	300	0.275	0.550	1.375	2.475	1980	4950	8910
VGS-0500-0600-300-30	Velogrid h x w - L=300 - Flange 30	500	600	300	0.300	0.600	1.500	2.700	2160	5400	9720
VGS-0500-0650-300-30	Velogrid h x w - L=300 - Flange 30	500	650	300	0.325	0.650	1.625	2.925	2340	5850	10530
VGS-0500-0700-300-30	Velogrid h x w - L=300 - Flange 30	500	700	300	0.350	0.700	1.750	3.150	2520	6300	11340
VGS-0500-0750-300-30	Velogrid h x w - L=300 - Flange 30	500	750	300	0.375	0.750	1.875	3.375	2700	6750	12150
VGS-0500-0800-300-30	Velogrid h x w - L=300 - Flange 30	500	800	300	0.400	0.800	2.000	3.600	2880	7200	12960
VGS-0500-0850-300-30	Velogrid h x w - L=300 - Flange 30	500	850	300	0.425	0.850	2.125	3.825	3060	7650	13770
VGS-0500-0900-300-30	Velogrid h x w - L=300 - Flange 30	500	900	300	0.450	0.900	2.250	4.050	3240	8100	14580
VGS-0500-0950-300-30	Velogrid h x w - L=300 - Flange 30	500	950	300	0.475	0.950	2.375	4.275	3420	8550	15390
VGS-0500-1000-300-30	Velogrid h x w - L=300 - Flange 30	500	1000	300	0.500	1.000	2.500	4.500	3600	9000	16200
VGS-0500-1050-300-30	Velogrid h x w - L=300 - Flange 30	500	1050	300	0.525	1.050	2.625	4.725	3780	9450	17010
VGS-0500-1100-300-30	Velogrid h x w - L=300 - Flange 30	500	1100	300	0.550	1.100	2.750	4.950	3960	9900	17820
VGS-0500-1150-300-30	Velogrid h x w - L=300 - Flange 30	500	1150	300	0.575	1.150	2.875	5.175	4140	10350	18630
VGS-0500-1200-300-30	Velogrid h x w - L=300 - Flange 30	500	1200	300	0.600	1.200	3.000	5.400	4320	10800	19440
VGS-0600-0200-300-30	Velogrid h x w - L=300 - Flange 30	600	200	300	0.120	0.240	0.600	1.080	864	2160	3888
VGS-0600-0250-300-30	Velogrid h x w - L=300 - Flange 30	600	250	300	0.150	0.300	0.750	1.350	1080	2700	4860
VGS-0600-0300-300-30	Velogrid h x w - L=300 - Flange 30	600	300	300	0.180	0.360	0.900	1.620	1296	3240	5832
VGS-0600-0350-300-30	Velogrid h x w - L=300 - Flange 30	600	350	300	0.210	0.420	1.050	1.890	1512	3780	6804
VGS-0600-0400-300-30	Velogrid h x w - L=300 - Flange 30	600	400	300	0.240	0.480	1.200	2.160	1728	4320	7776
VGS-0600-0450-300-30	Velogrid h x w - L=300 - Flange 30	600	450	300	0.270	0.540	1.350	2.430	1944	4860	8748
VGS-0600-0500-300-30	Velogrid h x w - L=300 - Flange 30	600	500	300	0.300	0.600	1.500	2.700	2160	5400	9720
VGS-0600-0550-300-30	Velogrid h x w - L=300 - Flange 30	600	550	300	0.330	0.660	1.650	2.970	2376	5940	10692
VGS-0600-0600-300-30	Velogrid h x w - L=300 - Flange 30	600	600	300	0.360	0.720	1.800	3.240	2592	6480	11664
VGS-0600-0650-300-30	Velogrid h x w - L=300 - Flange 30	600	650	300	0.390	0.780	1.950	3.510	2808	7020	12636
VGS-0600-0700-300-30	Velogrid h x w - L=300 - Flange 30	600	700	300	0.420	0.840	2.100	3.780	3024	7560	13608
VGS-0600-0750-300-30	Velogrid h x w - L=300 - Flange 30	600	750	300	0.450	0.900	2.250	4.050	3240	8100	14580
VGS-0600-0800-300-30	Velogrid h x w - L=300 - Flange 30	600	800	300	0.480	0.960	2.400	4.320	3456	8640	15552
VGS-0600-0850-300-30	Velogrid h x w - L=300 - Flange 30	600	850	300	0.510	1.020	2.550	4.590	3672	9180	16524
VGS-0600-0900-300-30	Velogrid h x w - L=300 - Flange 30	600	900	300	0.540	1.080	2.700	4.860	3888	9720	17496
VGS-0600-0950-300-30	Velogrid h x w - L=300 - Flange 30	600	950	300	0.570	1.140	2.850	5.130	4104	10260	18468
VGS-0600-1000-300-30	Velogrid h x w - L=300 - Flange 30	600	1000	300	0.600	1.200	3.000	5.400	4320	10800	19440
VGS-0600-1050-300-30	Velogrid h x w - L=300 - Flange 30	600	1050	300	0.630	1.260	3.150	5.670	4536	11340	20412
VGS-0600-1100-300-30	Velogrid h x w - L=300 - Flange 30	600	1100	300	0.660	1.320	3.300	5.940	4752	11880	21384
VGS-0600-1150-300-30	Velogrid h x w - L=300 - Flange 30	600	1150	300	0.690	1.380	3.450	6.210	4968	12420	22356
VGS-0600-1200-300-30	Velogrid h x w - L=300 - Flange 30	600	1200	300	0.720	1.440	3.600	6.480	5184	12960	23328

# VGS SPECIFICATIONS 30mm Flange Table 3

Part Number	Description	Height	width	depth	Area	Volume	Volume	Volume	Volume	Volume	Volume
		h	w	d		at 2 m/s	at 5 m/s	at 9 m/s	at 2 m/s	at 5 m/s	at 9 m/s
		mm	mm	mm	m <sup>2</sup>	m <sup>3</sup> /s	m <sup>3</sup> /s	m <sup>3</sup> /s	m <sup>3</sup> /h	m <sup>3</sup> /h	m <sup>3</sup> /h
VGS-0700-0200-300-30	Velogrid h x w - L=300 - Flange 30	700	200	300	0.140	0.280	0.700	1.260	1008	2520	4536
VGS-0700-0250-300-30	Velogrid h x w - L=300 - Flange 30	700	250	300	0.175	0.350	0.875	1.575	1260	3150	5670
VGS-0700-0300-300-30	Velogrid h x w - L=300 - Flange 30	700	300	300	0.210	0.420	1.050	1.890	1512	3780	6804
VGS-0700-0350-300-30	Velogrid h x w - L=300 - Flange 30	700	350	300	0.245	0.490	1.225	2.205	1764	4410	7938
VGS-0700-0400-300-30	Velogrid h x w - L=300 - Flange 30	700	400	300	0.280	0.560	1.400	2.520	2016	5040	9072
VGS-0700-0450-300-30	Velogrid h x w - L=300 - Flange 30	700	450	300	0.315	0.630	1.575	2.835	2268	5670	10206
VGS-0700-0500-300-30	Velogrid h x w - L=300 - Flange 30	700	500	300	0.350	0.700	1.750	3.150	2520	6300	11340
VGS-0700-0550-300-30	Velogrid h x w - L=300 - Flange 30	700	550	300	0.385	0.770	1.925	3.465	2772	6930	12474
VGS-0700-0600-300-30	Velogrid h x w - L=300 - Flange 30	700	600	300	0.420	0.840	2.100	3.780	3024	7560	13608
VGS-0700-0650-300-30	Velogrid h x w - L=300 - Flange 30	700	650	300	0.455	0.910	2.275	4.095	3276	8190	14742
VGS-0700-0700-300-30	Velogrid h x w - L=300 - Flange 30	700	700	300	0.490	0.980	2.450	4.410	3528	8820	15876
VGS-0700-0750-300-30	Velogrid h x w - L=300 - Flange 30	700	750	300	0.525	1.050	2.625	4.725	3780	9450	17010
VGS-0700-0800-300-30	Velogrid h x w - L=300 - Flange 30	700	800	300	0.560	1.120	2.800	5.040	4032	10080	18144
VGS-0700-0850-300-30	Velogrid h x w - L=300 - Flange 30	700	850	300	0.595	1.190	2.975	5.355	4284	10710	19278
VGS-0700-0900-300-30	Velogrid h x w - L=300 - Flange 30	700	900	300	0.630	1.260	3.150	5.670	4536	11340	20412
VGS-0700-0950-300-30	Velogrid h x w - L=300 - Flange 30	700	950	300	0.665	1.330	3.325	5.985	4788	11970	21546
VGS-0700-1000-300-30	Velogrid h x w - L=300 - Flange 30	700	1000	300	0.700	1.400	3.500	6.300	5040	12600	22680
VGS-0700-1050-300-30	Velogrid h x w - L=300 - Flange 30	700	1050	300	0.735	1.470	3.675	6.615	5292	13230	23814
VGS-0700-1100-300-30	Velogrid h x w - L=300 - Flange 30	700	1100	300	0.770	1.540	3.850	6.930	5544	13860	24948
VGS-0700-1150-300-30	Velogrid h x w - L=300 - Flange 30	700	1150	300	0.805	1.610	4.025	7.245	5796	14490	26082
VGS-0700-1200-300-30	Velogrid h x w - L=300 - Flange 30	700	1200	300	0.840	1.680	4.200	7.560	6048	15120	27216
VGS-0800-0200-300-30	Velogrid h x w - L=300 - Flange 30	800	200	300	0.160	0.320	0.800	1.440	1152	2880	5184
VGS-0800-0250-300-30	Velogrid h x w - L=300 - Flange 30	800	250	300	0.200	0.400	1.000	1.800	1440	3600	6480
VGS-0800-0300-300-30	Velogrid h x w - L=300 - Flange 30	800	300	300	0.240	0.480	1.200	2.160	1728	4320	7776
VGS-0800-0350-300-30	Velogrid h x w - L=300 - Flange 30	800	350	300	0.280	0.560	1.400	2.520	2016	5040	9072
VGS-0800-0400-300-30	Velogrid h x w - L=300 - Flange 30	800	400	300	0.320	0.640	1.600	2.880	2304	5760	10368
VGS-0800-0450-300-30	Velogrid h x w - L=300 - Flange 30	800	450	300	0.360	0.720	1.800	3.240	2592	6480	11664
VGS-0800-0500-300-30	Velogrid h x w - L=300 - Flange 30	800	500	300	0.400	0.800	2.000	3.600	2880	7200	12960
VGS-0800-0550-300-30	Velogrid h x w - L=300 - Flange 30	800	550	300	0.440	0.880	2.200	3.960	3168	7920	14256
VGS-0800-0600-300-30	Velogrid h x w - L=300 - Flange 30	800	600	300	0.480	0.960	2.400	4.320	3456	8640	15552
VGS-0800-0650-300-30	Velogrid h x w - L=300 - Flange 30	800	650	300	0.520	1.040	2.600	4.680	3744	9360	16848
VGS-0800-0700-300-30	Velogrid h x w - L=300 - Flange 30	800	700	300	0.560	1.120	2.800	5.040	4032	10080	18144
VGS-0800-0750-300-30	Velogrid h x w - L=300 - Flange 30	800	750	300	0.600	1.200	3.000	5.400	4320	10800	19440
VGS-0800-0800-300-30	Velogrid h x w - L=300 - Flange 30	800	800	300	0.640	1.280	3.200	5.760	4608	11520	20736
VGS-0800-0850-300-30	Velogrid h x w - L=300 - Flange 30	800	850	300	0.680	1.360	3.400	6.120	4896	12240	22032
VGS-0800-0900-300-30	Velogrid h x w - L=300 - Flange 30	800	900	300	0.720	1.440	3.600	6.480	5184	12960	23328
VGS-0800-0950-300-30	Velogrid h x w - L=300 - Flange 30	800	950	300	0.760	1.520	3.800	6.840	5472	13680	24624
VGS-0800-1000-300-30	Velogrid h x w - L=300 - Flange 30	800	1000	300	0.800	1.600	4.000	7.200	5760	14400	25920
VGS-0800-1050-300-30	Velogrid h x w - L=300 - Flange 30	800	1050	300	0.840	1.680	4.200	7.560	6048	15120	27216
VGS-0800-1100-300-30	Velogrid h x w - L=300 - Flange 30	800	1100	300	0.880	1.760	4.400	7.920	6336	15840	28512
VGS-0800-1150-300-30	Velogrid h x w - L=300 - Flange 30	800	1150	300	0.920	1.840	4.600	8.280	6624	16560	29808
VGS-0800-1200-300-30	Velogrid h x w - L=300 - Flange 30	800	1200	300	0.960	1.920	4.800	8.640	6912	17280	31104
VGS-0900-0200-300-30	Velogrid h x w - L=300 - Flange 30	900	200	300	0.180	0.360	0.900	1.620	1296	3240	5832
VGS-0900-0250-300-30	Velogrid h x w - L=300 - Flange 30	900	250	300	0.225	0.450	1.125	2.025	1620	4050	7290
VGS-0900-0300-300-30	Velogrid h x w - L=300 - Flange 30	900	300	300	0.270	0.540	1.350	2.430	1944	4860	8748
VGS-0900-0350-300-30	Velogrid h x w - L=300 - Flange 30	900	350	300	0.315	0.630	1.575	2.835	2268	5670	10206
VGS-0900-0400-300-30	Velogrid h x w - L=300 - Flange 30	900	400	300	0.360	0.720	1.800	3.240	2592	6480	11664
VGS-0900-0450-300-30	Velogrid h x w - L=300 - Flange 30	900	450	300	0.405	0.810	2.025	3.645	2916	7290	13122
VGS-0900-0500-300-30	Velogrid h x w - L=300 - Flange 30	900	500	300	0.450	0.900	2.250	4.050	3240	8100	14580
VGS-0900-0550-300-30	Velogrid h x w - L=300 - Flange 30	900	550	300	0.495	0.990	2.475	4.455	3564	8910	16038
VGS-0900-0600-300-30	Velogrid h x w - L=300 - Flange 30	900	600	300	0.540	1.080	2.700	4.860	3888	9720	17496
VGS-0900-0650-300-30	Velogrid h x w - L=300 - Flange 30	900	650	300	0.585	1.170	2.925	5.265	4212	10530	18954
VGS-0900-0700-300-30	Velogrid h x w - L=300 - Flange 30	900	700	300	0.630	1.260	3.150	5.670	4536	11340	20412
VGS-0900-0750-300-30	Velogrid h x w - L=300 - Flange 30	900	750	300	0.675	1.350	3.375	6.075	4860	12150	21870
VGS-0900-0800-300-30	Velogrid h x w - L=300 - Flange 30	900	800	300	0.720	1.440	3.600	6.480	5184	12960	23328
VGS-0900-0850-300-30	Velogrid h x w - L=300 - Flange 30	900	850	300	0.765	1.530	3.825	6.885	5508	13770	24786
VGS-0900-0900-300-30	Velogrid h x w - L=300 - Flange 30	900	900	300	0.810	1.620	4.050	7.290	5832	14580	26244
VGS-0900-0950-300-30	Velogrid h x w - L=300 - Flange 30	900	950	300	0.855	1.710	4.275	7.695	6156	15390	27702
VGS-0900-1000-300-30	Velogrid h x w - L=300 - Flange 30	900	1000	300	0.900	1.800	4.500	8.100	6480	16200	29160
VGS-0900-1050-300-30	Velogrid h x w - L=300 - Flange 30	900	1050	300	0.945	1.890	4.725	8.505	6804	17010	30618
VGS-0900-1100-300-30	Velogrid h x w - L=300 - Flange 30	900	1100	300	0.990	1.980	4.950	8.910	7128	17820	32076
VGS-0900-1150-300-30	Velogrid h x w - L=300 - Flange 30	900	1150	300	1.035	2.070	5.175	9.315	7452	18630	33534
VGS-0900-1200-300-30	Velogrid h x w - L=300 - Flange 30	900	1200	300	1.080	2.160	5.400	9.720	7776	19440	34992

# VGS SPECIFICATIONS 30mm Flange Table 4

Part Number	Description	Height	width	depth	Area	Volume	Volume	Volume	Volume	Volume	Volume
		h	w	d		at 2 m/s	at 5 m/s	at 9 m/s	at 2 m/s	at 5 m/s	at 9 m/s
		mm	mm	mm	m2	m3/s	m3/s	m3/s	m3/h	m3/h	m3/h
VGS-1000-0200-300-30	Velogrid h x w - L=300 - Flange 30	1000	200	300	0.200	0.400	1.000	1.800	1440	3600	6480
VGS-1000-0250-300-30	Velogrid h x w - L=300 - Flange 30	1000	250	300	0.250	0.500	1.250	2.250	1800	4500	8100
VGS-1000-0300-300-30	Velogrid h x w - L=300 - Flange 30	1000	300	300	0.300	0.600	1.500	2.700	2160	5400	9720
VGS-1000-0350-300-30	Velogrid h x w - L=300 - Flange 30	1000	350	300	0.350	0.700	1.750	3.150	2520	6300	11340
VGS-1000-0400-300-30	Velogrid h x w - L=300 - Flange 30	1000	400	300	0.400	0.800	2.000	3.600	2880	7200	12960
VGS-1000-0450-300-30	Velogrid h x w - L=300 - Flange 30	1000	450	300	0.450	0.900	2.250	4.050	3240	8100	14580
VGS-1000-0500-300-30	Velogrid h x w - L=300 - Flange 30	1000	500	300	0.500	1.000	2.500	4.500	3600	9000	16200
VGS-1000-0550-300-30	Velogrid h x w - L=300 - Flange 30	1000	550	300	0.550	1.100	2.750	4.950	3960	9900	17820
VGS-1000-0600-300-30	Velogrid h x w - L=300 - Flange 30	1000	600	300	0.600	1.200	3.000	5.400	4320	10800	19440
VGS-1000-0650-300-30	Velogrid h x w - L=300 - Flange 30	1000	650	300	0.650	1.300	3.250	5.850	4680	11700	21060
VGS-1000-0700-300-30	Velogrid h x w - L=300 - Flange 30	1000	700	300	0.700	1.400	3.500	6.300	5040	12600	22680
VGS-1000-0750-300-30	Velogrid h x w - L=300 - Flange 30	1000	750	300	0.750	1.500	3.750	6.750	5400	13500	24300
VGS-1000-0800-300-30	Velogrid h x w - L=300 - Flange 30	1000	800	300	0.800	1.600	4.000	7.200	5760	14400	25920
VGS-1000-0850-300-30	Velogrid h x w - L=300 - Flange 30	1000	850	300	0.850	1.700	4.250	7.650	6120	15300	27540
VGS-1000-0900-300-30	Velogrid h x w - L=300 - Flange 30	1000	900	300	0.900	1.800	4.500	8.100	6480	16200	29160
VGS-1000-0950-300-30	Velogrid h x w - L=300 - Flange 30	1000	950	300	0.950	1.900	4.750	8.550	6840	17100	30780
VGS-1000-1000-300-30	Velogrid h x w - L=300 - Flange 30	1000	1000	300	1.000	2.000	5.000	9.000	7200	18000	32400
VGS-1000-1050-300-30	Velogrid h x w - L=300 - Flange 30	1000	1050	300	1.050	2.100	5.250	9.450	7560	18900	34020
VGS-1000-1100-300-30	Velogrid h x w - L=300 - Flange 30	1000	1100	300	1.100	2.200	5.500	9.900	7920	19800	35640
VGS-1000-1150-300-30	Velogrid h x w - L=300 - Flange 30	1000	1150	300	1.150	2.300	5.750	10.350	8280	20700	37260
VGS-1000-1200-300-30	Velogrid h x w - L=300 - Flange 30	1000	1200	300	1.200	2.400	6.000	10.800	8640	21600	38880
VGS-1100-0200-300-30	Velogrid h x w - L=300 - Flange 30	1100	200	300	0.220	0.440	1.100	1.980	1584	3960	7128
VGS-1100-0250-300-30	Velogrid h x w - L=300 - Flange 30	1100	250	300	0.275	0.550	1.375	2.475	1980	4950	8910
VGS-1100-0300-300-30	Velogrid h x w - L=300 - Flange 30	1100	300	300	0.330	0.660	1.650	2.970	2376	5940	10692
VGS-1100-0350-300-30	Velogrid h x w - L=300 - Flange 30	1100	350	300	0.385	0.770	1.925	3.465	2772	6930	12474
VGS-1100-0400-300-30	Velogrid h x w - L=300 - Flange 30	1100	400	300	0.440	0.880	2.200	3.960	3168	7920	14256
VGS-1100-0450-300-30	Velogrid h x w - L=300 - Flange 30	1100	450	300	0.495	0.990	2.475	4.455	3564	8910	16038
VGS-1100-0500-300-30	Velogrid h x w - L=300 - Flange 30	1100	500	300	0.550	1.100	2.750	4.950	3960	9900	17820
VGS-1100-0550-300-30	Velogrid h x w - L=300 - Flange 30	1100	550	300	0.605	1.210	3.025	5.445	4356	10890	19602
VGS-1100-0600-300-30	Velogrid h x w - L=300 - Flange 30	1100	600	300	0.660	1.320	3.300	5.940	4752	11880	21384
VGS-1100-0650-300-30	Velogrid h x w - L=300 - Flange 30	1100	650	300	0.715	1.430	3.575	6.435	5148	12870	23166
VGS-1100-0700-300-30	Velogrid h x w - L=300 - Flange 30	1100	700	300	0.770	1.540	3.850	6.930	5544	13860	24948
VGS-1100-0750-300-30	Velogrid h x w - L=300 - Flange 30	1100	750	300	0.825	1.650	4.125	7.425	5940	14850	26730
VGS-1100-0800-300-30	Velogrid h x w - L=300 - Flange 30	1100	800	300	0.880	1.760	4.400	7.920	6336	15840	28512
VGS-1100-0850-300-30	Velogrid h x w - L=300 - Flange 30	1100	850	300	0.935	1.870	4.675	8.415	6732	16830	30294
VGS-1100-0900-300-30	Velogrid h x w - L=300 - Flange 30	1100	900	300	0.990	1.980	4.950	8.910	7128	17820	32076
VGS-1100-0950-300-30	Velogrid h x w - L=300 - Flange 30	1100	950	300	1.045	2.090	5.225	9.405	7524	18810	33858
VGS-1100-1000-300-30	Velogrid h x w - L=300 - Flange 30	1100	1000	300	1.100	2.200	5.500	9.900	7920	19800	35640
VGS-1100-1050-300-30	Velogrid h x w - L=300 - Flange 30	1100	1050	300	1.155	2.310	5.775	10.395	8316	20790	37422
VGS-1100-1100-300-30	Velogrid h x w - L=300 - Flange 30	1100	1100	300	1.210	2.420	6.050	10.890	8712	21780	39204
VGS-1100-1150-300-30	Velogrid h x w - L=300 - Flange 30	1100	1150	300	1.265	2.530	6.325	11.385	9108	22770	40986
VGS-1100-1200-300-30	Velogrid h x w - L=300 - Flange 30	1100	1200	300	1.320	2.640	6.600	11.880	9504	23760	42768
VGS-1200-0200-300-30	Velogrid h x w - L=300 - Flange 30	1200	200	300	0.240	0.480	1.200	2.160	1728	4320	7776
VGS-1200-0250-300-30	Velogrid h x w - L=300 - Flange 30	1200	250	300	0.300	0.600	1.500	2.700	2160	5400	9720
VGS-1200-0300-300-30	Velogrid h x w - L=300 - Flange 30	1200	300	300	0.360	0.720	1.800	3.240	2592	6480	11664
VGS-1200-0350-300-30	Velogrid h x w - L=300 - Flange 30	1200	350	300	0.420	0.840	2.100	3.780	3024	7560	13608
VGS-1200-0400-300-30	Velogrid h x w - L=300 - Flange 30	1200	400	300	0.480	0.960	2.400	4.320	3456	8640	15552
VGS-1200-0450-300-30	Velogrid h x w - L=300 - Flange 30	1200	450	300	0.540	1.080	2.700	4.860	3888	9720	17496
VGS-1200-0500-300-30	Velogrid h x w - L=300 - Flange 30	1200	500	300	0.600	1.200	3.000	5.400	4320	10800	19440
VGS-1200-0550-300-30	Velogrid h x w - L=300 - Flange 30	1200	550	300	0.660	1.320	3.300	5.940	4752	11880	21384
VGS-1200-0600-300-30	Velogrid h x w - L=300 - Flange 30	1200	600	300	0.720	1.440	3.600	6.480	5184	12960	23328
VGS-1200-0650-300-30	Velogrid h x w - L=300 - Flange 30	1200	650	300	0.780	1.560	3.900	7.020	5616	14040	25272
VGS-1200-0700-300-30	Velogrid h x w - L=300 - Flange 30	1200	700	300	0.840	1.680	4.200	7.560	6048	15120	27216
VGS-1200-0750-300-30	Velogrid h x w - L=300 - Flange 30	1200	750	300	0.900	1.800	4.500	8.100	6480	16200	29160
VGS-1200-0800-300-30	Velogrid h x w - L=300 - Flange 30	1200	800	300	0.960	1.920	4.800	8.640	6912	17280	31104
VGS-1200-0850-300-30	Velogrid h x w - L=300 - Flange 30	1200	850	300	1.020	2.040	5.100	9.180	7344	18360	33048
VGS-1200-0900-300-30	Velogrid h x w - L=300 - Flange 30	1200	900	300	1.080	2.160	5.400	9.720	7776	19440	34992
VGS-1200-0950-300-30	Velogrid h x w - L=300 - Flange 30	1200	950	300	1.140	2.280	5.700	10.260	8208	20520	36936
VGS-1200-1000-300-30	Velogrid h x w - L=300 - Flange 30	1200	1000	300	1.200	2.400	6.000	10.800	8640	21600	38880
VGS-1200-1050-300-30	Velogrid h x w - L=300 - Flange 30	1200	1050	300	1.260	2.520	6.300	11.340	9072	22680	40824
VGS-1200-1100-300-30	Velogrid h x w - L=300 - Flange 30	1200	1100	300	1.320	2.640	6.600	11.880	9504	23760	42768
VGS-1200-1150-300-30	Velogrid h x w - L=300 - Flange 30	1200	1150	300	1.380	2.760	6.900	12.420	9936	24840	44712
VGS-1200-1200-300-30	Velogrid h x w - L=300 - Flange 30	1200	1200	300	1.440	2.880	7.200	12.960	10368	25920	46656